

Condair FF2

Adiabatic High-Pressure Humidifier



INSTALLATION AND OPERATING INSTRUCTIONS

Contents

1	Introduction	4	6	Initial commissioning	36
1.1	To the very beginning	4	6.1	Check list initial commissioning Condair FF2	36
1.2	Notes on the installation and operating instructions	4	7	Operation	38
2	For your safety	6	7.1	Display and operating elements	38
3	Overview of Condair FF2	8	7.2	Setting the unit into operation	39
3.1	Condair FF2 system overview	8	7.3	Inspections during operation	40
3.1.1	Stand-alone system (master configuration)	8	7.4	Setting the unit out of service	40
3.1.2	Compound system (master-slave configuration)	9	8	Maintenance and replacement of components	41
3.2	Pump station	10	8.1	Important notes on maintenance	41
3.3	Humidifier unit	12	8.2	Maintenance intervals	42
3.4	Functional description	14	8.3	Maintenance work	42
3.5	Scope of delivery	17	8.4	Resetting the maintenance indication	43
4	Notes on planning	18	8.5	Removal of components	44
4.1	Record of site-specific data	18	8.5.1	Removal and installation of spray nozzles	44
4.2	Accessories and options	19	8.5.2	Replacement of piston packings	44
5	Installation works	20	8.6	Changing the oil of the piston pump	45
5.1	Important notes on installation	20	9	Troubleshooting	46
5.2	Mounting of the nozzle unit	20	9.1	Important notes on troubleshooting	46
5.2.1	Notes on positioning and mounting of the nozzle unit	20	9.2	Malfunction with error indication	46
5.2.2	Mounting the nozzle unit	21	9.3	Resetting the error indication	46
5.3	Mounting the pump station	26	9.4	Malfunction without error indication	47
5.3.1	Notes on positioning and mounting the pump station	26	9.5	Replacing the fuse of the control unit	49
5.3.2	Dimension and weights of pump station	27	10	Product data	50
5.3.3	Mounting the pump station	28	10.1	Technical specifications/ambient conditions	50
5.3.4	Water installation	29	10.2	Declaration of conformity	51
5.4	Mounting the control unit FF2 Slave	31	10	Appendix	52
5.5	Electrical installation	32	10.1	Diagram h,x	52
5.5.1	Wiring diagram Master units (stand-alone units)	32			
5.5.2	Wiring diagram Slave units	33			
5.5.3	Notes on electric installation	34			

1 Introduction

1.1 To the very beginning

We thank you for having purchased the **Condair FF2 Adiabatic High Pressure Humidifier** (“Condair FF2” for short).

The Condair FF2 incorporates the latest technical advances and meets all recognized safety standards. Nevertheless, improper use of the Condair FF2 may result in danger to the user or third parties and/or impairment of material assets.

To ensure a safe, proper, and economical operation of the steam humidifier Condair FF2, please observe and comply with all information and safety instructions contained in the present installation and operating instructions as well as the instructions given in the manuals for the components used in the humidification system.

If you have questions, which are not or insufficiently answered in this documentation, please contact your Condair supplier. They will be glad to assist you.

1.2 Notes on the installation and operating instructions

Limitation

The subject of these installation and operating instructions is Condair FF2 Adiabatic High Pressure Humidifier. The various accessories are only described insofar as this is necessary for proper operation of the equipment. Further information on accessories can be obtained in the respective instructions.

These installation and operating instructions are restricted to the **installation, commissioning, operation, servicing and trouble shooting** of the Condair FF2 and is meant for **well trained personnel being sufficiently qualified for their respective work.**

These installation and operating instructions are supplemented by various separate items of documentation (installation drawings, technical specifications, etc.). Where necessary, appropriate cross-references are made to these publications in the installation and operating instructions.

Symbols used in this manual

CAUTION!

The catchword "CAUTION" designates notes in this installation and operating instructions that, if neglected, may cause **damage and/or malfunction of the unit or other material assets**.

WARNING!

The catchword "WARNING" used in conjunction with the general caution symbol designates safety and danger notes in this installation and operating instructions that, if neglected, may cause to **injury to persons**.

DANGER!

The catchword "DANGER" used in conjunction with the general caution symbol designates safety and danger notes in this installation and operating instructions that, if neglected, may lead to **severe injury or even death of persons**.

Safekeeping

Please safeguard these installation and operating instructions in a safe place, where they can be immediately accessed. If the equipment changes hands, the documentation must be passed on to the new operator.

If the documentation gets mislaid, please contact your Condair supplier.

Language versions

These installation and operating instructions are available in various languages. Please contact your Condair supplier for information.

Copyright protection

The present installation and operating instructions is protected under the Copyright Act. Passing-on and reproduction of the manual (or part thereof) as well as exploitation and communication of the contents are prohibited without written permission by the manufacturer. Violation of copyright terms is subject to legal prosecution and arises liability for indemnification.

The manufacturer reserves the right to fully exploit commercial patent rights.

2 For your safety

General

Every person working with the Condair FF2 must have read and understood the installation and operating instructions before carrying out any work.

Knowing and understanding the contents of the installation and operating instructions is a basic requirement for protecting the personnel against any kind of danger, to prevent faulty operation, and to operate the unit safely and correctly.

All ideograms, signs and markings applied to the unit must be observed and kept in readable state.

Qualification of personnel

All actions described in the present installation and operating instructions (installation, operation, maintenance, etc.) must be carried out only by **well trained and sufficiently qualified personnel authorised by the owner**.

For safety and warranty reasons any action beyond the scope of this manuals must be carried out only by qualified personnel authorised by the manufacturer.

It is assumed that all persons working with the Condair FF2 are familiar and comply with the appropriate regulations on work safety and the prevention of accidents.

Intended use

The Condair FF2 is intended exclusively for **humidification in ventilation systems within the specified operating conditions** (see chapter 10 "Product specifications"). Any other type of application without the express written consent of the manufacturer is considered as not conforming with the intended purpose and may lead to the Condair FF2 becoming dangerous.

Operation of the equipment in the intended manner requires **that all the information in these installation and operating instructions is observed (in particular the safety instructions)**

Danger that may arise from the unit

CAUTION! Danger of electric shock

One may get in touch with live parts when the pump station/ control unit is open. Touching live parts may cause severe injury or danger to life..

Prevention: before carrying out any work on the Condair FF2, set the unit out of operation as described in chapter 7.4 (switch off the unit, disconnect it from the mains and stop the water supply) and secure the unit against inadvertent power-up.

WARNING!

Poorly maintained humidification systems may endanger health. When insufficiently maintained harmful germs can build up in the air duct and affect the duct air.

Prevention: as described in chapter 8 "Maintenance", the Condair FF2 must be cleaned in the specified intervals and the cleaning work must be carried out correctly.

WARNING!

During operation the water system is at high pressure. Inappropriately fastened hoses can be torn out of the screw connections during operation by the high pressure. There is danger of injury, in no circumstances loosen any hoses or screw connections during operation.

Prevention: always correctly tighten the high pressure hoses and screw connections and do not loosen any hoses or screw connections during operation. Before carrying out any work on the Condair FF2, set the unit out of operation as described in chapter 7.4 (switch off the unit, disconnect it from the mains and stop the water supply) and secure the unit against inadvertent power-up.

Behaviour in case of danger

If it is suspected that safe operation is no longer possible, then the Condair FF2 should immediately be shut down and secured against accidental power-up according to chapter 7.4 (switch off systems, disconnect it from the mains and stop the water supply). This can be the case under the following circumstances:

- if components of the Condair FF2 are damaged, worn or badly soiled.
- if the Condair FF2 does not work correctly.
- if connectors and lines are leaking.
- after longtime storage under unfavourable conditions.
- after transportation under unfavourable conditions.

All persons working with the Condair FF2 must report any alterations to the unit that may affect safety to the owner without delay.

Prohibited modifications to the unit

No modifications must be undertaken on the Condair FF2 without the express written consent of the manufacturer.

For the replacement of defective components use exclusively **original accessories and spare parts** available from your Condair supplier.

3 Overview of Condair FF2

3.1 Condair FF2 system overview

3.1.1 Stand-alone system (master configuration)

Humidifier unit consisting of:

- 1 Step valves Y3, Y4 and Y5
- 2 Nozzle unit
- 3 Droplet separator (option or product of other manufacturer)
- 4 Flushing valve high pressure system (option)

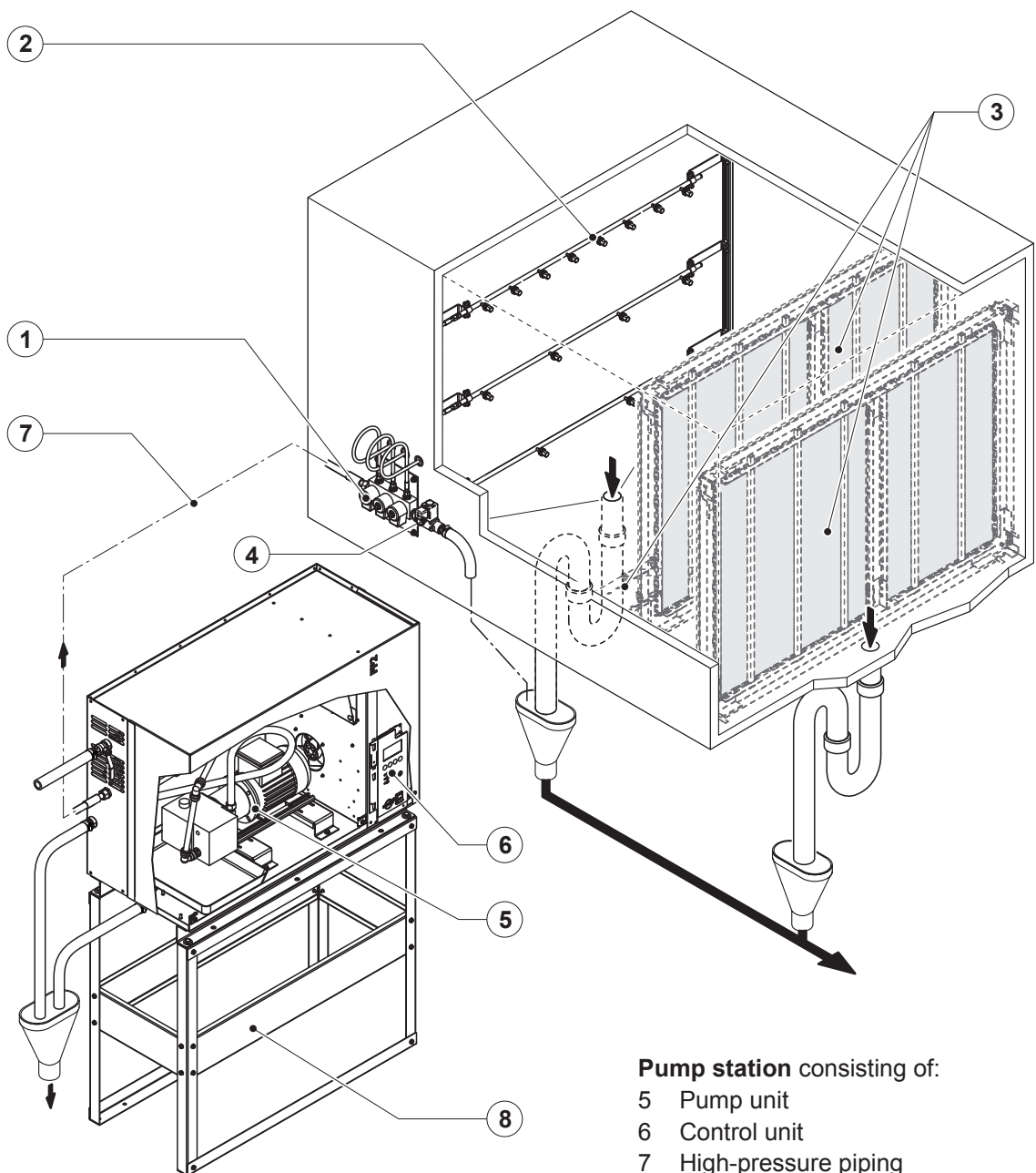

Pump station consisting of:

- 5 Pump unit
- 6 Control unit
- 7 High-pressure piping
- 8 Floor stand (option)

3.1.2 Compound system (master-slave configuration)

Assuming the maximum pump capacity is sufficient, the pump station of a stand-alone system may supply pressurized water to up to three further FF2 systems building a so-called master-slave configuration as shown below.

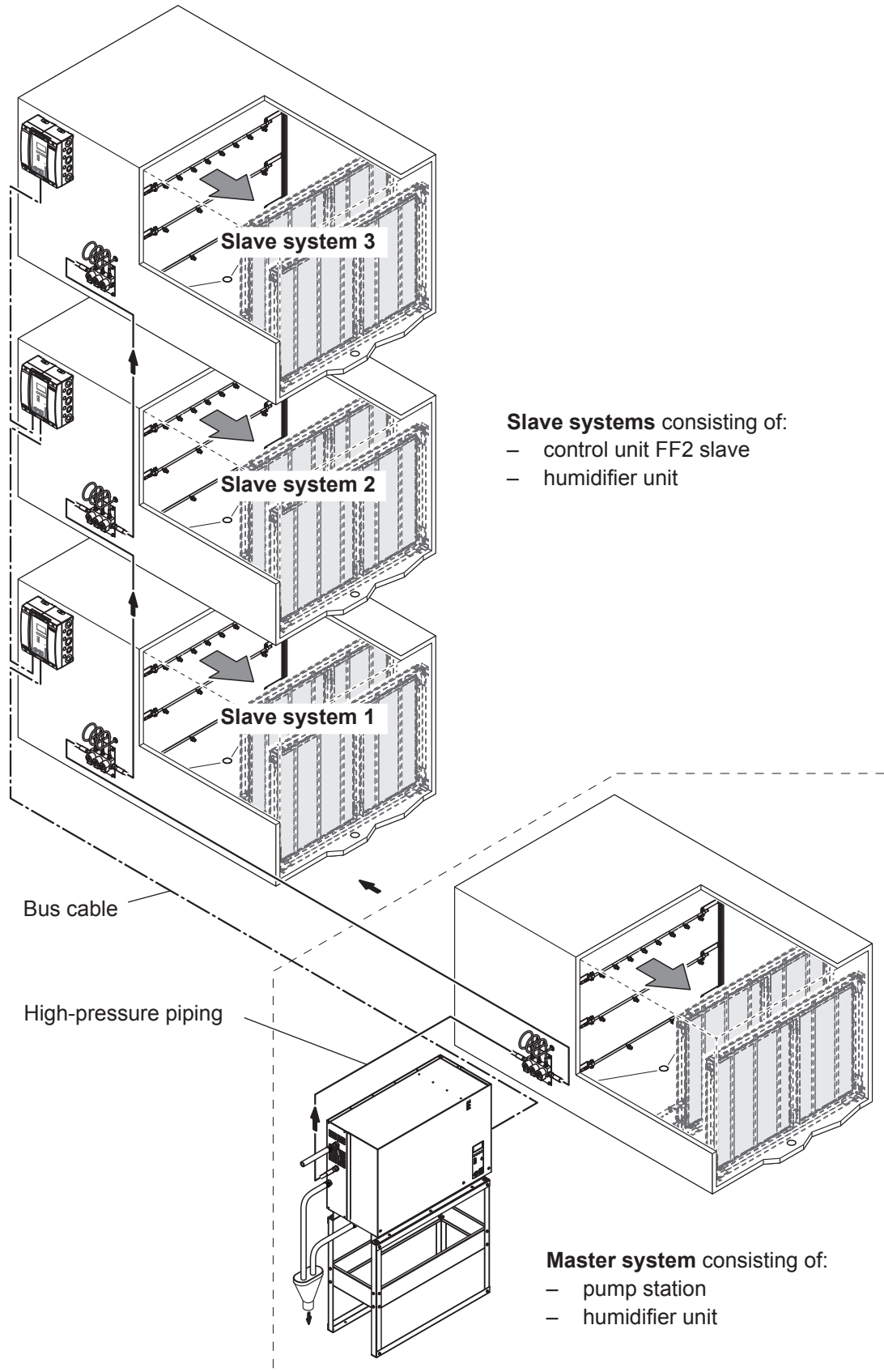

3.2 Pump station

Overview

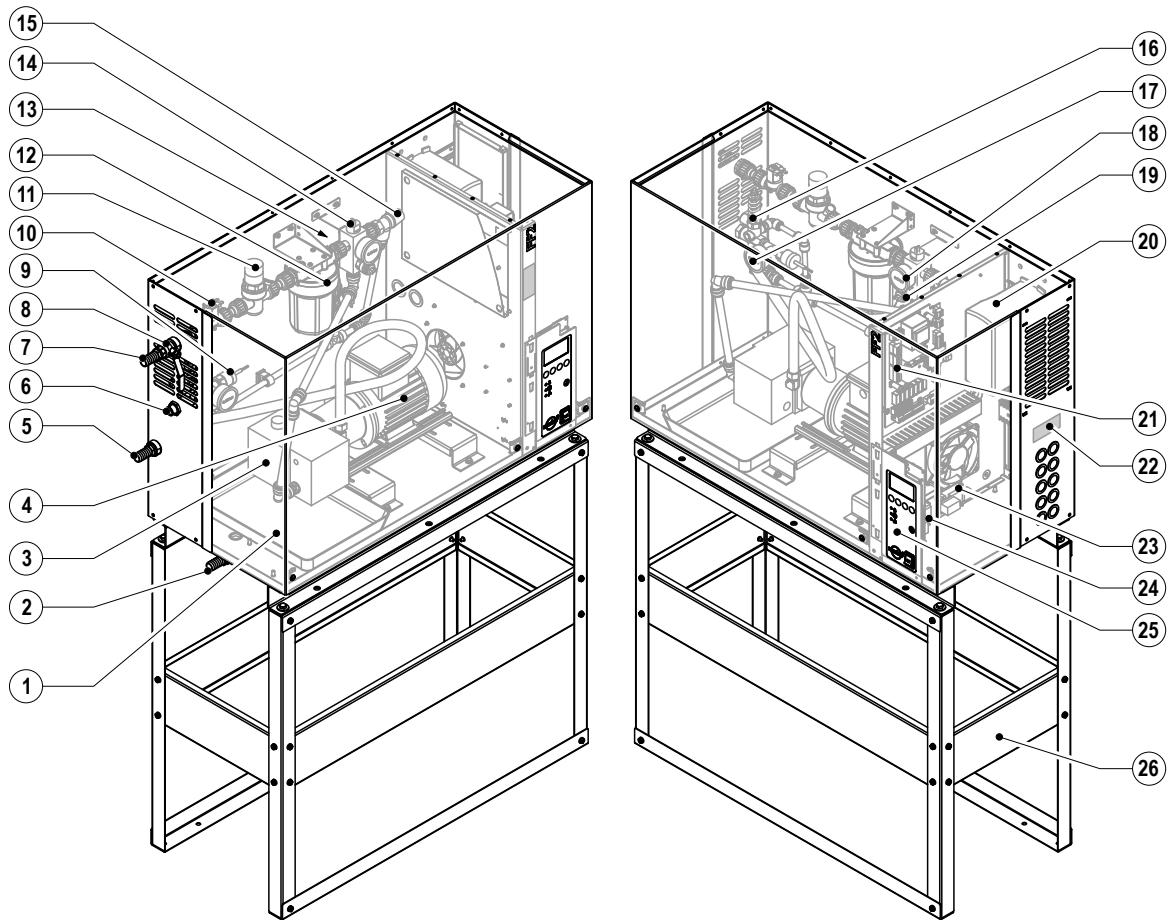

- | | |
|---|---|
| 1 Oil pan | 14 Conductivity sensor (option) |
| 2 Connector housing drain | 15 Safety valve supply pressure |
| 3 Jetting pump | 16 Safety valve working pressure |
| 4 Pump motor | 17 Manometer working pressure |
| 5 Flush/relief connector | 18 Manometer supply pressure |
| 6 High-pressure connector | 19 Minimum pressure switch (supply pressure) |
| 7 Supply connector | 20 Frequency converter pump motor |
| 8 Stop valve | 21 Driver board |
| 9 Pressure transmitter (working pressure) | 22 Rating plate |
| 10 Supply valve | 23 BMS gateway (option e-LINKS FF2) |
| 11 Pressure reducing valve | 24 Remote operation/fault indication board (option) |
| 12 Water filter | 25 Display and control unit with control |
| 13 Flushing valve (supply) | 26 Floor stand (option) |

Brief description of pump station

The pump station consists of the control unit and the pump unit and it is supplied in a housing ready for connection.

Pump unit: The oil-lubricated high pressure pump is directly mounted to the electric motor and reaches the maximum capacity of 1'080 kg/h at an operating pressure of 80 bar. Assuming the maximum pump capacity is sufficient, up to three further FF2 systems may be connected to the jetting pump via the high-pressure circular piping.

A minimum pressure switch continuously monitors the minimum supply pressure and a pressure transmitter continuously monitors the minimum working pressure. They stop pump operation in case the minimum pressure values drop below the limit for a certain time. Two safety valves ensure that the maximum supply pressure and the maximum working pressure are not exceeded. The pressure reducing valve maintains constant supply pressure.

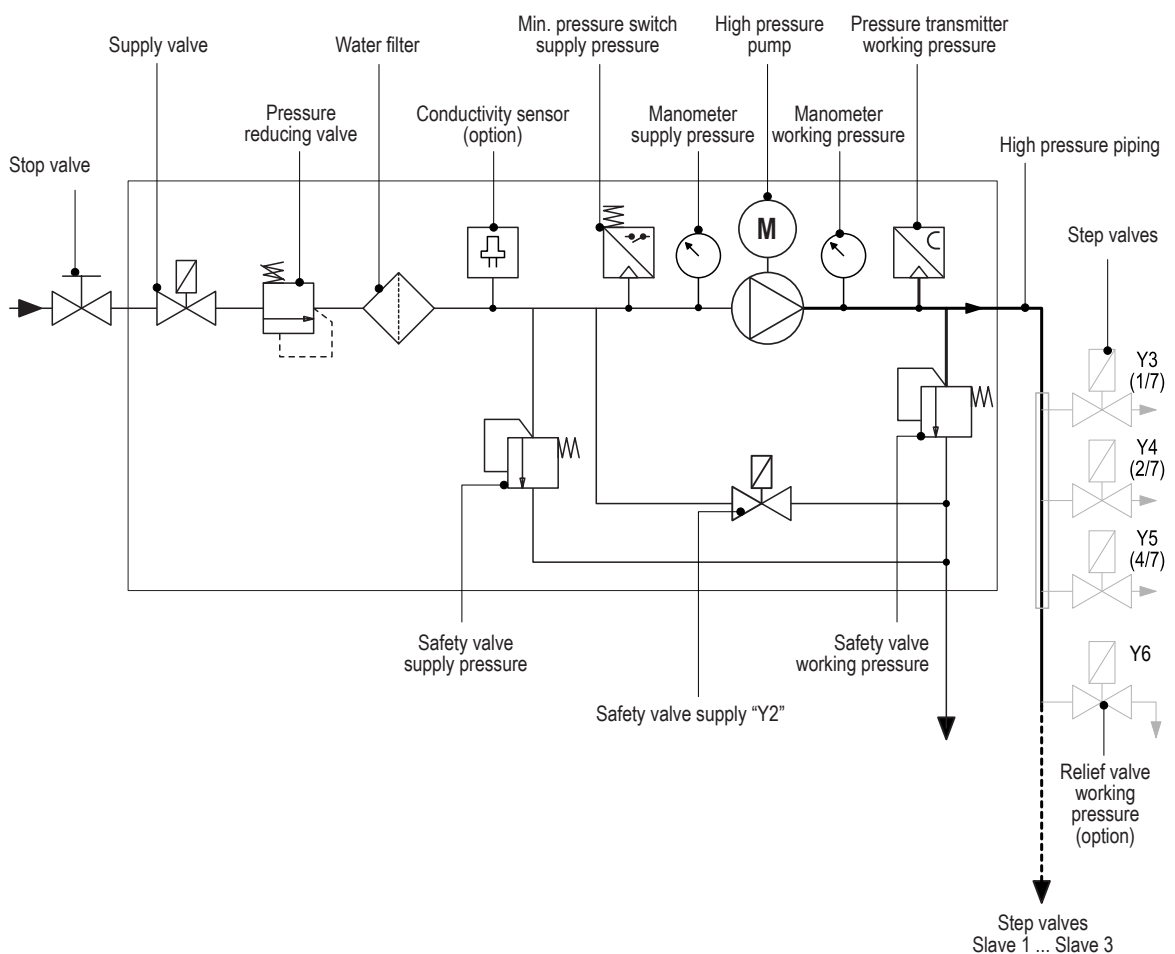

At the installation site, the supply line of demineralized water, the high-pressure hose of the piping (accessory) and the drain must be connected to the jetting pump.

Control unit: the control unit consists of the display and control unit, the driver board, the frequency converter for the control of the high pressure pump and the connection terminals for the power supply (380...400V/3N~/50-60Hz). Optionally the control unit can be equipped with a remote operating and fault indication print, a conductivity monitoring and a BMS gateway (e-LINKS FF2) for the integration into a building management system (BMS).

The pump station is electrically wired at the factory. At the installation site, the power supply, the humidity controller or humidity sensor, the remote operating and fault indication (option), the external safety chain and the step valves must be electrically connected to the control unit.

3.3 Humidifier unit

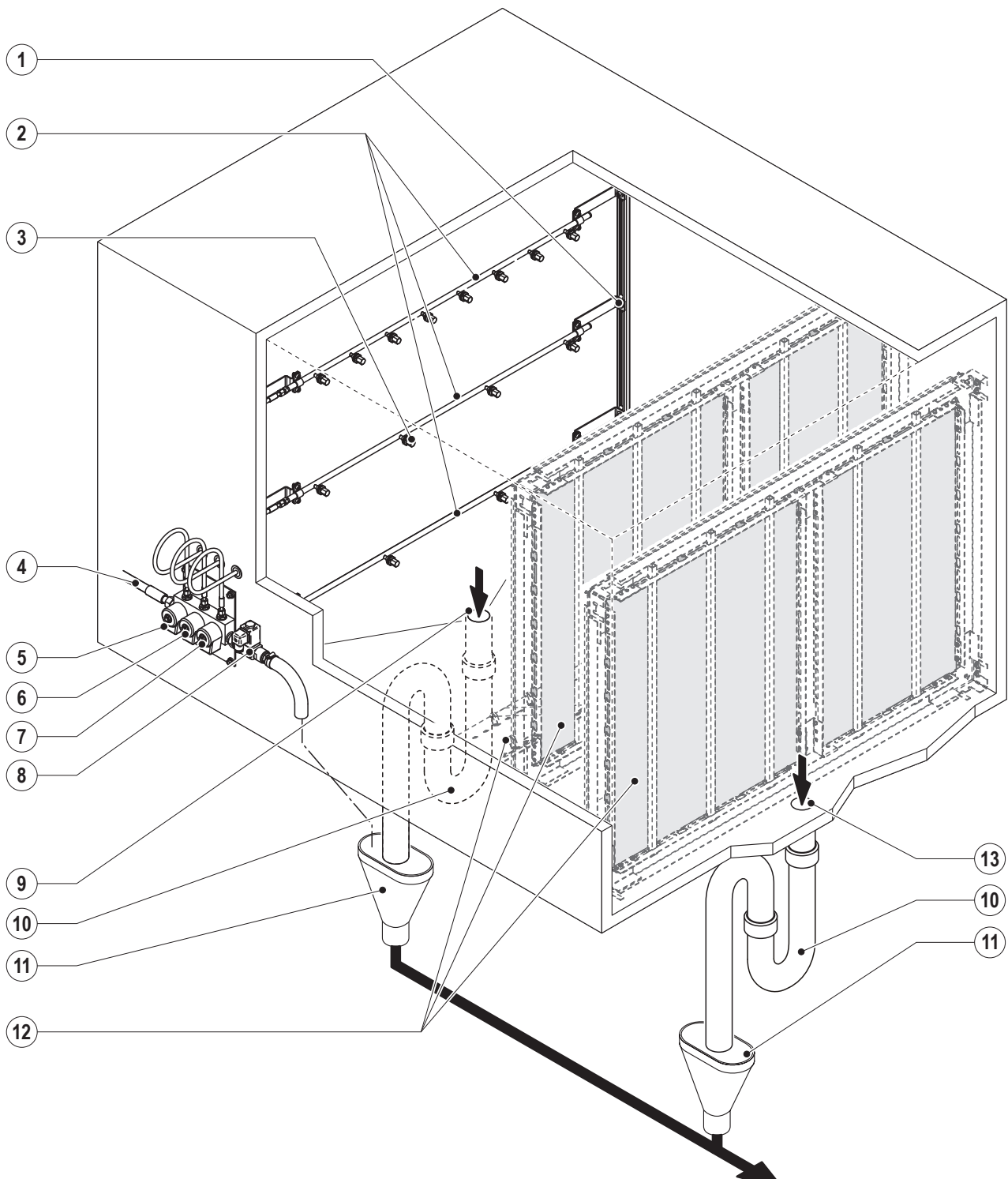

- 1 Supporting structure nozzle unit
- 2 Nozzle pipes
- 3 Spray nozzle
- 4 High-pressure piping from pump station
- 5 Step valve Y3 (1/7)
- 6 Step valve Y4 (2/7)
- 7 Step valve Y5 (4/7)
- 8 Flushing valve Y6 working pressure (option)

- 9 Water drain after nozzles
- 10 Siphon (by customers, height adapted to duct pressure)
- 11 Open drain funnel (by customers)
- 12 Droplet separator (option or product of other manufacturer)
- 13 Water drain after humidifier unit

Nozzle unit

The nozzle unit consists of several nozzle pipes, which are equipped with the necessary number of nozzles (system-specific). The individual nozzle pipes are divided into three different spray circuits (1/7, 2/7 and 4/7). The spray circuits are connected via a high pressure hoses to the corresponding step valves (either directly or via a distribution blocks).

Droplet separator

The installation of a droplet separator is the customers responsibility. An optional droplet separator is available for the Condair FF2 (see opposite illustration). Detailed information regarding the optional droplet separator can be found in the separate documentation to this product.

3.4 Functional description

Elementary diagram of Condair FF2 (stand-alone system)

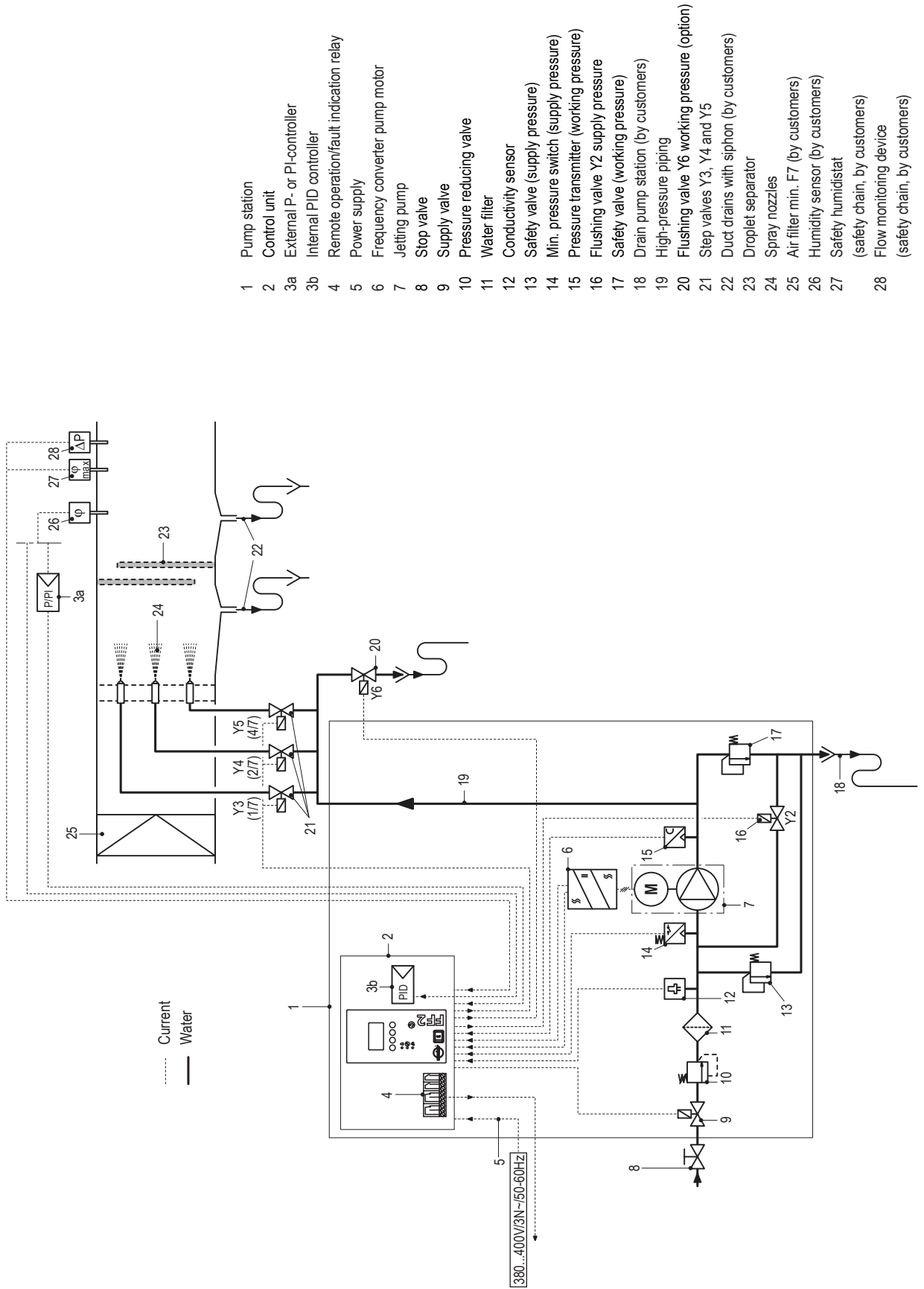

- 1 Pump station
- 2 Control unit
- 3a External P- or PI-controller
- 3b Internal PID controller
- 4 Remote operation/fault indication relay
- 5 Power supply
- 6 Frequency converter pump motor
- 7 Jetting pump
- 8 Stop valve
- 9 Supply valve
- 10 Pressure reducing valve
- 11 Water filter
- 12 Conductivity sensor
- 13 Safety valve (supply pressure)
- 14 Min. pressure switch (supply pressure)
- 15 Pressure transmitter (working pressure)
- 16 Flushing valve Y2 supply pressure
- 17 Safety valve (working pressure)
- 18 Drain pump station (by customers)
- 19 High-pressure piping
- 20 Flushing valve Y6 working pressure (option)
- 21 Step valves Y3, Y4 and Y5
- 22 Duct drains with siphon (by customers)
- 23 Droplet separator
- 24 Spray nozzles
- 25 Air filter min. F7 (by customers)
- 26 Humidity sensor (by customers)
- 27 Safety humidistat (safety chain, by customers)
- 28 Flow monitoring device (safety chain, by customers)

Elementary diagram of Condair FF2 (master-slave compound configuration)

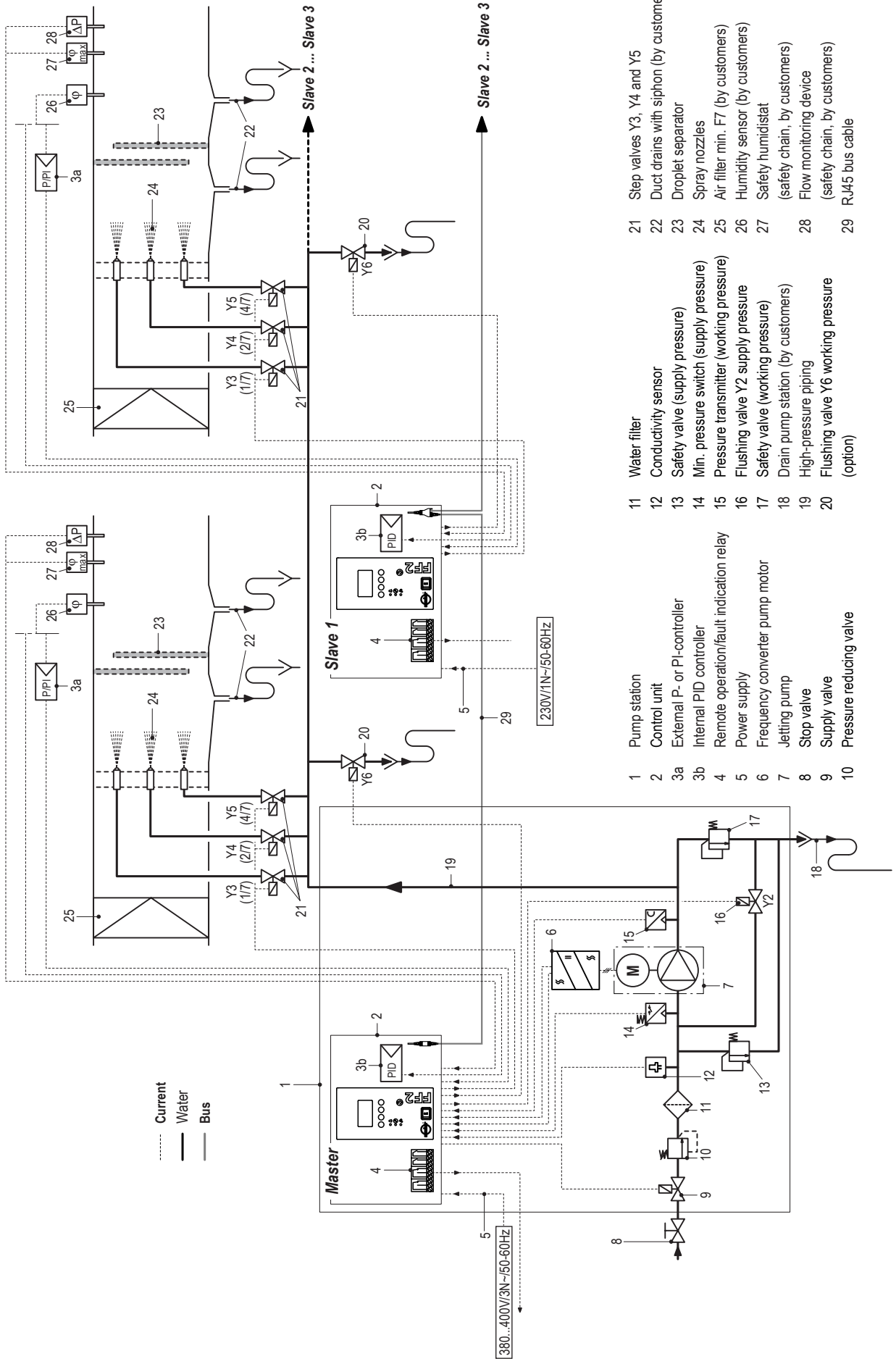

- 1 Pump station
- 2 Control unit
- 3a External P- or PI-controller
- 3b Internal PID controller
- 4 Remote operation/fault indication relay
- 5 Power supply
- 6 Frequency converter pump motor
- 7 Jetting pump
- 8 Stop valve
- 9 Supply valve
- 10 Pressure reducing valve
- 11 Water filter
- 12 Conductivity sensor
- 13 Safety valve (supply pressure)
- 14 Min. pressure switch (supply pressure)
- 15 Pressure transmitter (working pressure)
- 16 Flushing valve Y2 supply pressure
- 17 Safety valve (working pressure)
- 18 Drain pump station (by customers)
- 19 High-pressure piping
- 20 Flushing valve Y6 working pressure (option)
- 21 Step valves Y3, Y4 and Y5
- 22 Duct drains with siphon (by customers)
- 23 Droplet separator
- 24 Spray nozzles
- 25 Air filter min. F7 (by customers)
- 26 Humidity sensor (by customers)
- 27 Safety humidistat (safety chain, by customers)
- 28 Flow monitoring device (safety chain, by customers)
- 29 RJ45 bus cable

General

Via the stop valve (8) the fully demineralized water (also called permeate) is fed from the reversing osmosis system (RO system) to the pump station (1).

If the control unit is operational and a humidification request is present, the supply valve (9) and the flushing valve (16) open simultaneously and the pump circuit is flushed. After a certain time the flushing valve (16) closes again. If the supply pressure is within the admissible range the jetting pump (7) starts and builds up the required working pressure. The jetting pump feeds the water to the step valves (21) via the high-pressure piping (19). One, two or all three step valves open, depending on the humidification required (see step diagram below).

The demineralized water then flows to the respective spray nozzles (24) where it is atomized into a fine aerosol mist and absorbed by the air passing by.

A droplet separator (23) (option or product of other manufacturer) downstream make sure no aerosols are carried over to the air passing by. Waste water flows down from the droplet separators to the duct drains (22) and the siphons.

If there is no humidification request the pump automatically stops after a short time.

Control

With stand-alone systems (master configuration) the control unit is built into the pump station. The control unit features a separate power supply (380...400V/3N~/50-60Hz), a control/humidity signal input, connectors for the external safety chain and relay connectors for the remote operation and fault indication (option). In addition, the control unit incorporates the frequency converter for the control of the jetting pump.

With compound systems, each slave is equipped with a separate control unit. Each control unit features a separate power supply (230V/1N~/50-60Hz), a control/humidity signal input, connectors for the external safety chain and relay connectors for the remote operation and fault indication (option). A bus cable (29) connects each slave control unit to the control unit of the master system that controls the jetting pump.

Humidification

The control of the humidification system is established via an external P/PI controller (3a) or the PID controller built into the control unit (3b).

As standard the humidification is effected with 7-stages in accordance with the following diagram. Finer gradations are possible. Contact your Condair supplier if necessary.

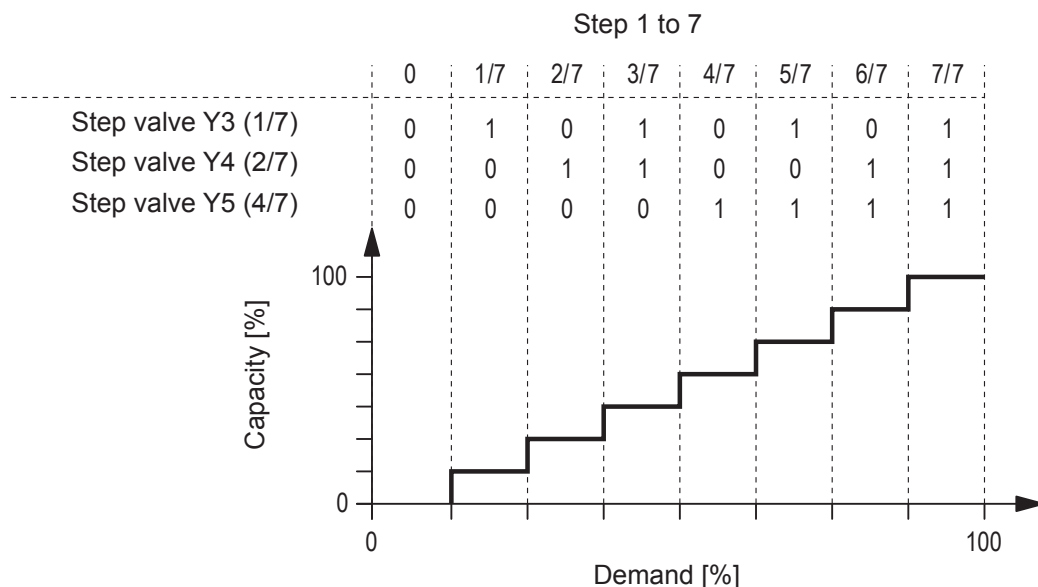

Monitoring of jetting pump

The minimum supply and working pressure values are permanently monitored. The jetting pump automatically stops if one of these values is outside the admissible range. A respective error message appears in the display, the red lamp "Error" lights up.

In addition to the electronic monitoring the jetting pump is equipped with two mechanical safety valves for the supply and working pressure. These valves open if the admissible supply pressure or working pressure are exceeded.

In addition, the control unit of the pump station and the valve control units can be equipped with a remote operating and fault indication print. Thus the following operating conditions can be displayed over the appropriate relays: "Error", "Humidification", "Maintenance" and "Unit on".

3.5 Scope of delivery

The delivery includes:

- Pump station complete with control unit and built-in PID controller and optional items as ordered according chapter 4.3.
- Nozzle unit including mounting accessories
- High-pressure hoses (2 m, 5 m or 10 m) for high-pressure piping
- 3 m anti-chafe spiral hose
- RJ45 Bus cable (20 m or 10 m, other lengths available on request), for compound systems only
- Special cable to step valves Y3, Y4 and Y5
- Installation and operating instructions (the document you are currently reading)
- Installation drawing with mounting dimensions
- Tubing diagram

4 Notes on planning

Prior to designing and selecting a Condair FF2 humidification system the following preparatory steps must be carried out:

- Collecting site-specific data required for system design (see chapter 4.1)
- Selecting the desired options (see chapter 4.2)

4.1 Record of site-specific data

Your Condair representative needs the following data for proper system design:

Duct dimensions		
Width (inner)	mm	_____
Height (inner)	mm	_____
Length (inner, min. 1300 mm)	mm	_____
Wall thickness of duct in the area of the water tubing pass-through	mm	_____
Air velocity in duct, or	m/s	_____
air volume to be humidified per hour	m ³ /h	_____
Air pressure (absolute) in housing --> not mandatory necessarily	Pa	_____
State of supply air prior to humidification		
Temperature T1	°C	_____
Humidity x1	g/kg / %rh	_____
Desired state of air after humidification		
Temperature T2	°C	_____
Humidity x2	g/kg / %rh	_____

Important notes:

- If a particular site is to be equipped with several FF2 systems determine the above data for each system separately. Your Condair representative will then evaluate whether the particular systems may be operated in a master-slave compound configuration.
- Evaporating aerosols cools down the air inside the duct (adiabatic cooling effect). To achieve the desired air temperature the supply air must be heated prior to humidification.

4.2 Accessories and options

Accessories

Accessory	Description
High-pressure hose for high-pressure piping	High-pressure hoses for establishing the high-pressure piping between the high-pressure connectors of the pump. Hoses of 2 m, 5 m or 10 m length available (from stock)
Anti-chafe spiral hose	The anti-chafe spiral hose protects the high-pressure hoses in locations where they are subject to get in touch with each other or with other system components. Length: 3 m
RJ45 bus cable	The bus cable connects the control units of a master-slave configuration. Length: 10 m or 20 m

Options

Option	Floor stand for pump station
Floor stand for pump station	Floor stand made of corrosion resistant steel, for mounting the pump station at a convenient height for easy operation.
Droplet separator	Droplet separator in frame construction made of corrosion resistant steel equipped with collector meshes with a special biocide coating. With unfavourable flow conditions and/or high air speed in the duct additionally a deflection sheet is provided for the optimization of the incident air flow of the first droplet separator.
Remote operating and fault indication	Print with relay contacts for the remote indication of the following operating conditions: Unit on, Humidification, Error and Maintenance.
Conductivity monitoring	The conductivity monitoring, consisting of the conductivity sensor and the conductivity print, monitors the electrical conductivity of the water and outputs an error message if the lower limit value is exceeded.
Flushing valve Y6	Flushing valve for the automatic flushing of the high pressure piping during operation. The flushing valve is installed directly to the step valve block.
e-LINKS FF2	Gateway to connect the Condair FF2 to a building management system. Two versions are available: BACnet/IP or LonWorks

5 Installation works

5.1 Important notes on installation

Qualification of personnel

All installation work must be performed **only by persons familiar with the Condair FF2 Adiabatic High Pressure Humidifier and sufficiently qualified for such work.**

All work concerning the electric installation must be performed only by adequately qualified personnel (electrician or workman with equivalent training).

Safety

For all installation work the ventilation system in which the Condair FF2 will be installed is to be rendered inoperative and prevented from further inadvertent operation.

The pump station and possible Slave control units may be connected to electric mains only after all installation work has been completed.

General notes

All statements relating to the correct positioning and installation of the particular components of the Condair FF2 (see chapter 5.2 and 5.3) **must be followed and complied with.**

When installing components of the Condair FF2 use **the fixing materials supplied with the unit.** If fixing with the materials supplied is not possible in your particular case, select a method of fixing that is of similar stability. In case of doubt, please contact your Condair supplier.

5.2 Mounting of the nozzle unit

5.2.1 Notes on positioning and mounting of the nozzle unit

The system-specific dimensions for the positioning of the nozzle unit in the duct are to be found in the installation documents, which are provided with your system.

In addition to the installation instructions please observe the following complementary notes on mounting:

- **Caution, fully demineralized water is aggressive!** The Condair FF2 system uses fully demineralized water. All components (duct/monoblock, mounting accessories, drain line, etc.) in the humidifier unit area must be made of **stainless steel** (DIN 1.4301/AISI 304 or better) or **plastic resistant to fully demineralized water.**
- For the installation and maintenance of the humidifier unit the ventilation duct/monoblock must be equipped with a **viewing window** and a sufficiently large **maintenance access door.**
- In the humidifier unit area the ventilation duct/monoblock must be waterproof.
- If the ambient air is cold the ventilation duct must be isolated to prevent the humidified air from condensating at the walls.
- **Important! At the site of installation an air filter meeting the F7 quality specifications or better must be installed before the humidifier unit.**

- The section of the duct holding the humidifier unit must be equipped with a tub having two water drains, one before and one after the droplet separators. Make sure the water in the tub has unhampered access to the drains. Each water drain must be connected to the sewage system separately, via a siphon. For hygienic reasons these should be open drains to the sewage line of the site.
Important: The effective height of the siphon depends on the duct pressure. The proper layout of the draining system is the customer's duty.
- The minimum distance of 0,4 m between the humidifier unit and a possible heating unit as well as the mounting dimensions according to the system diagram must be complied with.
- To prevent water drops from breaking away at the droplet separators the air flow to the humidifier unit must be uniform with regard to the entire diameter. Air rectifiers or perforated plates must be installed before the humidifier unit, as required.
- The admissible air velocity in the duct before the humidifier unit is 0.5 ... 4.0 m/s.
- If silencers are installed in the air conditioning unit, make sure they are installed with a minimum distance of 3 m before or after the Condair FF2.

5.2.2 Mounting the nozzle unit

1. **Installing the vertical mounting rails:** mark the position of the fixing straps at the duct wall, then drill the $\varnothing 3.3$ mm fixing holes.

Important! Make sure that the fixing holes in the left and right duct wall are exactly aligned opposite each other and that the axes of the upper and lower fixing holes are at right angles to the ceiling of the duct.

Then, fix the vertical mounting rails to the wall of the duct with the fixing straps and the self-tapping screws provided.

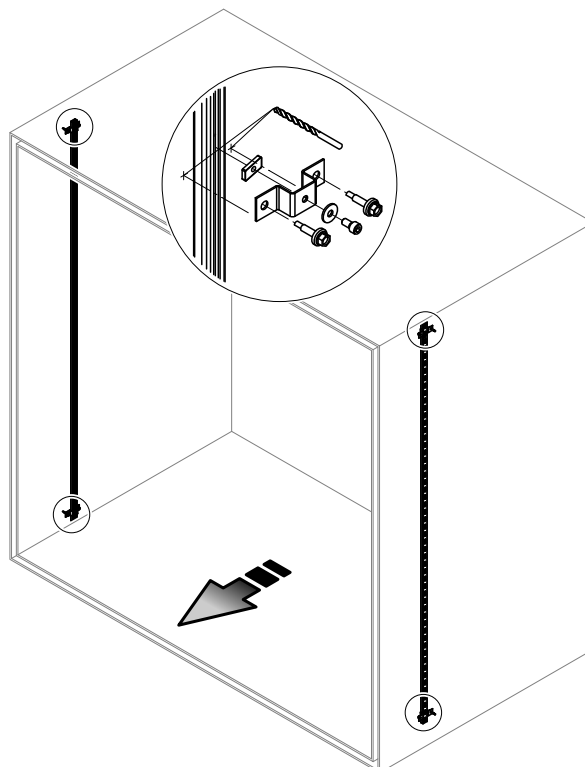

- Mounting the pipe supports:** Fix the pipe supports to the vertical mounting rails using the screws and sliding nuts provided (vertical position according to the installation drawing).
Important! Align opposite pipe supports exactly horizontal.

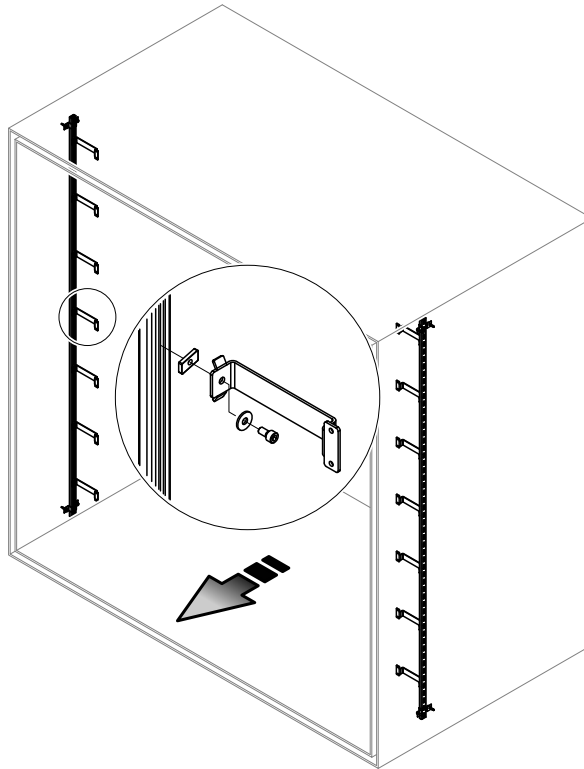

- Mounting the nozzle pipes:** Fix nozzle pipes to the pipe supports using the fixing straps, screws and washers provided (positioning of the nozzle pipes according to the installation drawing). Before tightening the fixing straps, make sure the outlet openings of the nozzles are aligned exactly horizontal in flow direction.

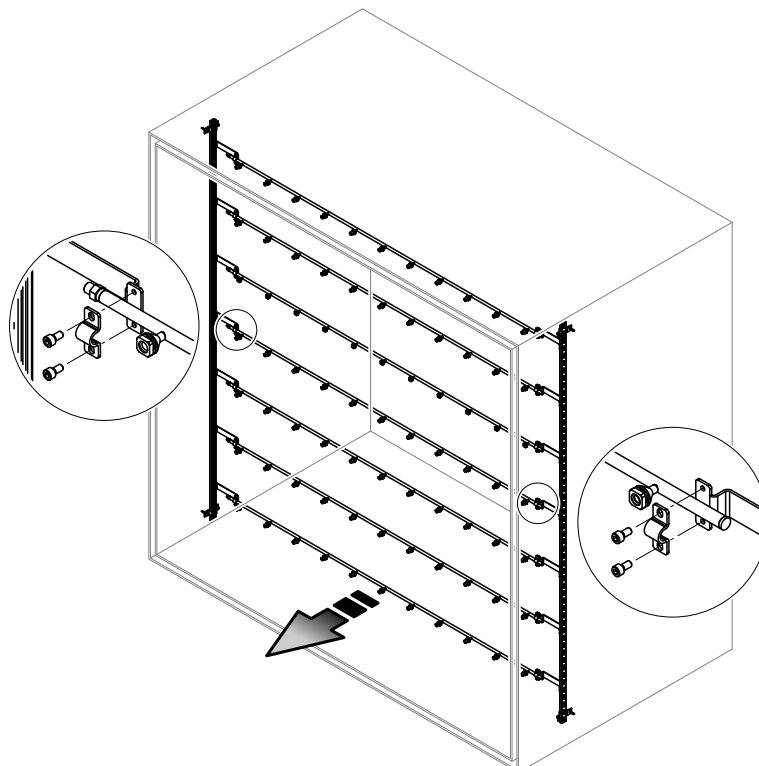

4. **Mounting the central support rail (only for ducts with a width $a > 2$ m):** Fix central support rail to the nozzle pipes using the fixing straps, screws, washers and sliding nuts provided. Fix lower and upper angle bracket to the central support rail using the screws, washers and sliding nuts provided. Finally fix the angle brackets to the duct ceiling and the duct bottom using the self-tapping screws provided (first drill the $\varnothing 3.3$ mm holes).

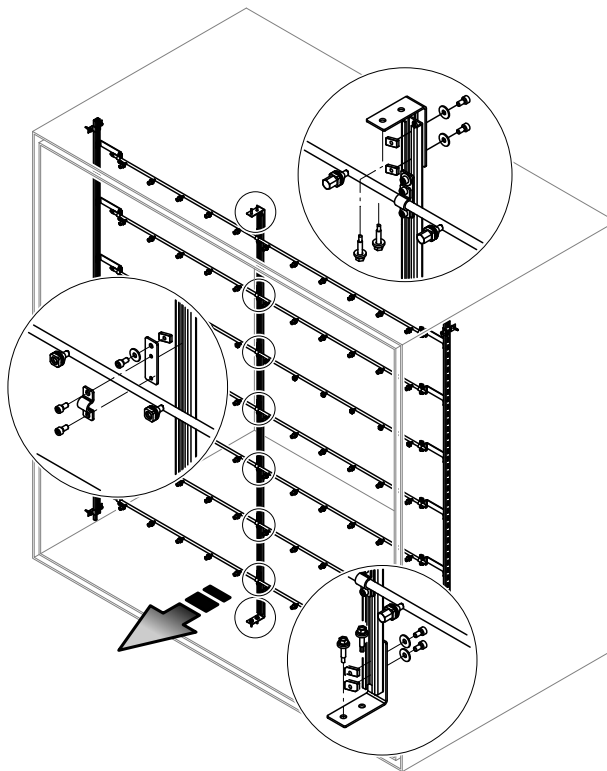

5. **Mounting the distribution blocks (systems with more than three nozzle pipes only):** Fix distribution blocks to the vertical mounting rails using the screws and washers provided (positioning according to the installation drawing).

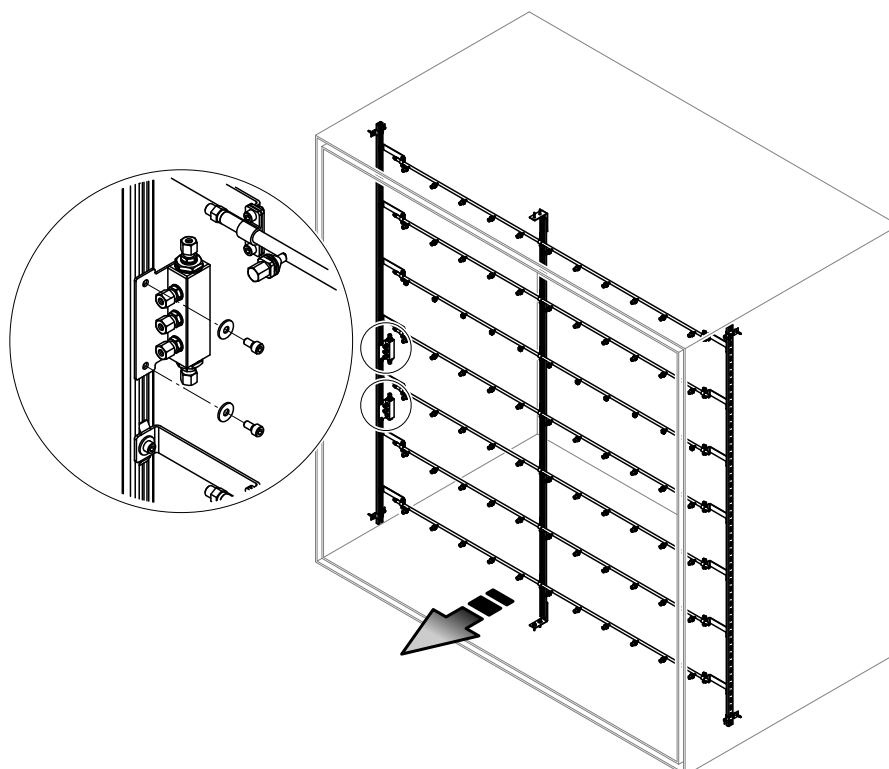

6. **Mounting the step valve block:** Fix the step valve block at the appropriate position to the duct using the self-tapping screws provided. Then, drill duct passages $\varnothing 32.5$ mm and close the holes inside and outside with the rubber sleeves provided.

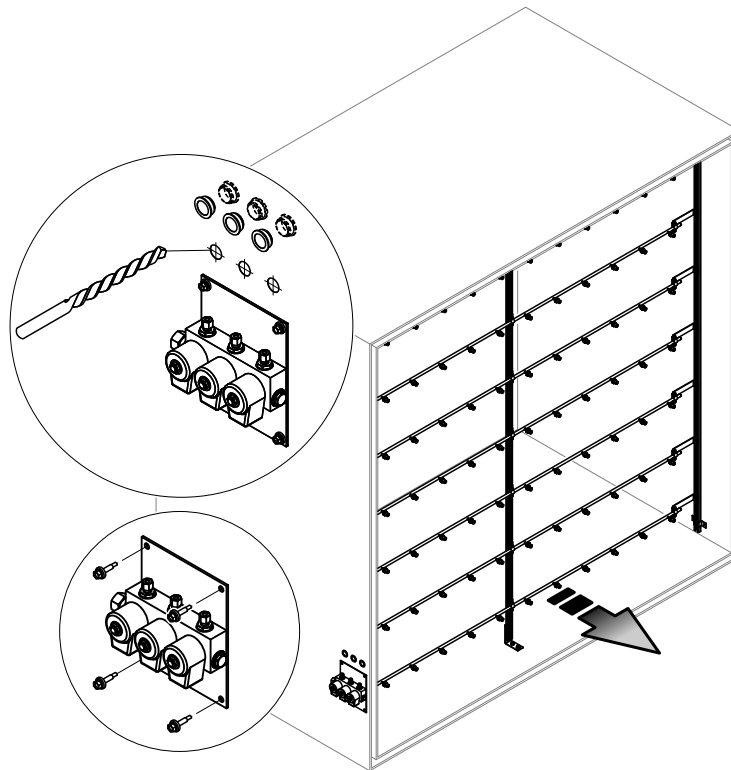

7. **Connecting the high-pressure hoses to the step valve block:** Connect the high-pressure hoses to the step valve block, then lead the hoses through the rubber sleeves into the duct as shown in the illustration below.

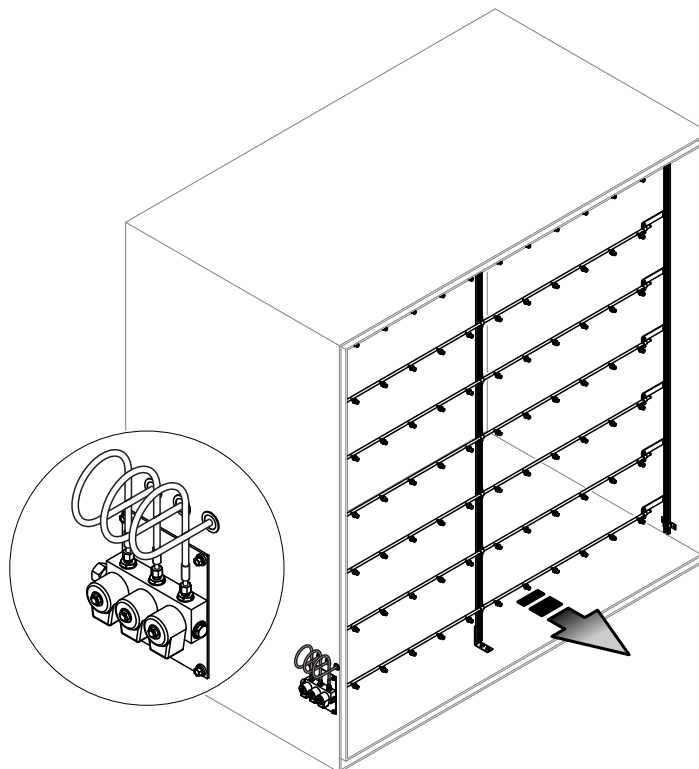

8. **Connecting the high-pressure hoses to the spray circuits:** Connect the high-pressure hoses to the appropriate distribution blocks and nozzle pipes (position of the spray circuits according to the installation drawing). Make sure the hoses are not kinked (if necessary, lead hoses in a bow to the connector).

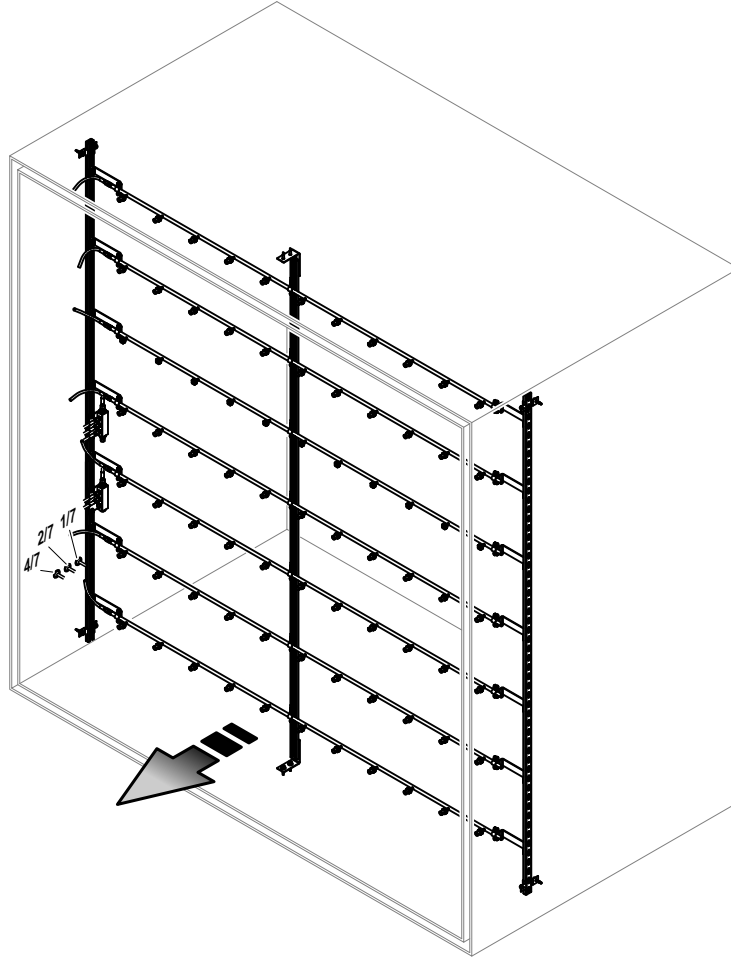

5.3 Mounting the pump station

5.3.1 Notes on positioning and mounting the pump station

Please observe the following notes on positioning and mounting:

- Place the pump station in a way that:
 - the distance to the humidifier unit is as short as possible.
Note: High-pressure hoses of 2 m, 5 m or 10 m length are available from stock.
 - it is freely accessible and there is enough space for convenient operation and maintenance (**min. free space around pump station: laterally 0.5 m, in front 0.6 m**).
- The pump station is designed for the operation in protected rooms and must therefore not be installed outside.
- Do not install the pump station in exposed locations or locations with heavy dust load.
- The **pump station** must be installed only in a **location having a water drain** on the floor. If this is not possible, it is mandatory to provide **water sensors** to safely interrupt water supply in case of leakage. Furthermore, choose a suitable location that prevents damage to material assets in case of leakage.
- The **pump station** is designed for installation on a load-carrying floor or on the optional floor stand. The pump station or the floor stand must be fixed with screws to the floor (protection against shifting and tilting).

Caution! Do not install the pump station to vibrating components.

5.3.2 Dimension and weights of pump station

all dimensions in mm

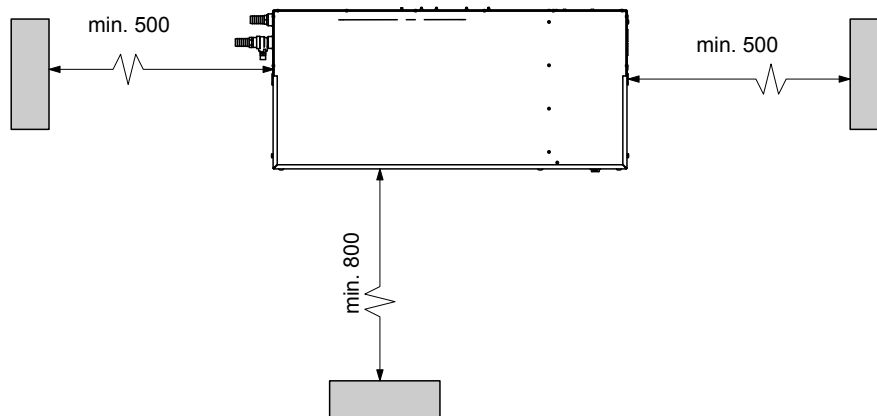
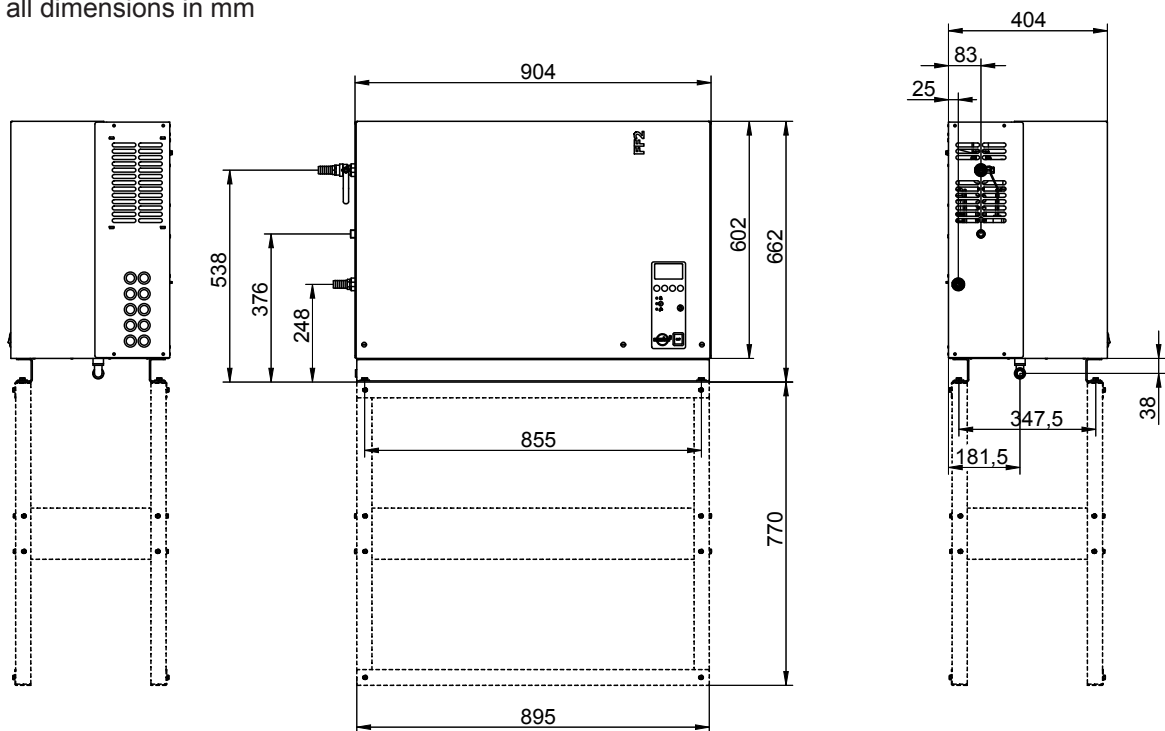

Weight of pump station: **approx. 80 kg**
 Weight of floor stand: **approx. 6 kg**

5.3.3 Mounting the pump station

Mount the pump station at the desired location in accordance with the following figure directly to the floor (left figure) or mount the unit on the optional floor stand (right figure).

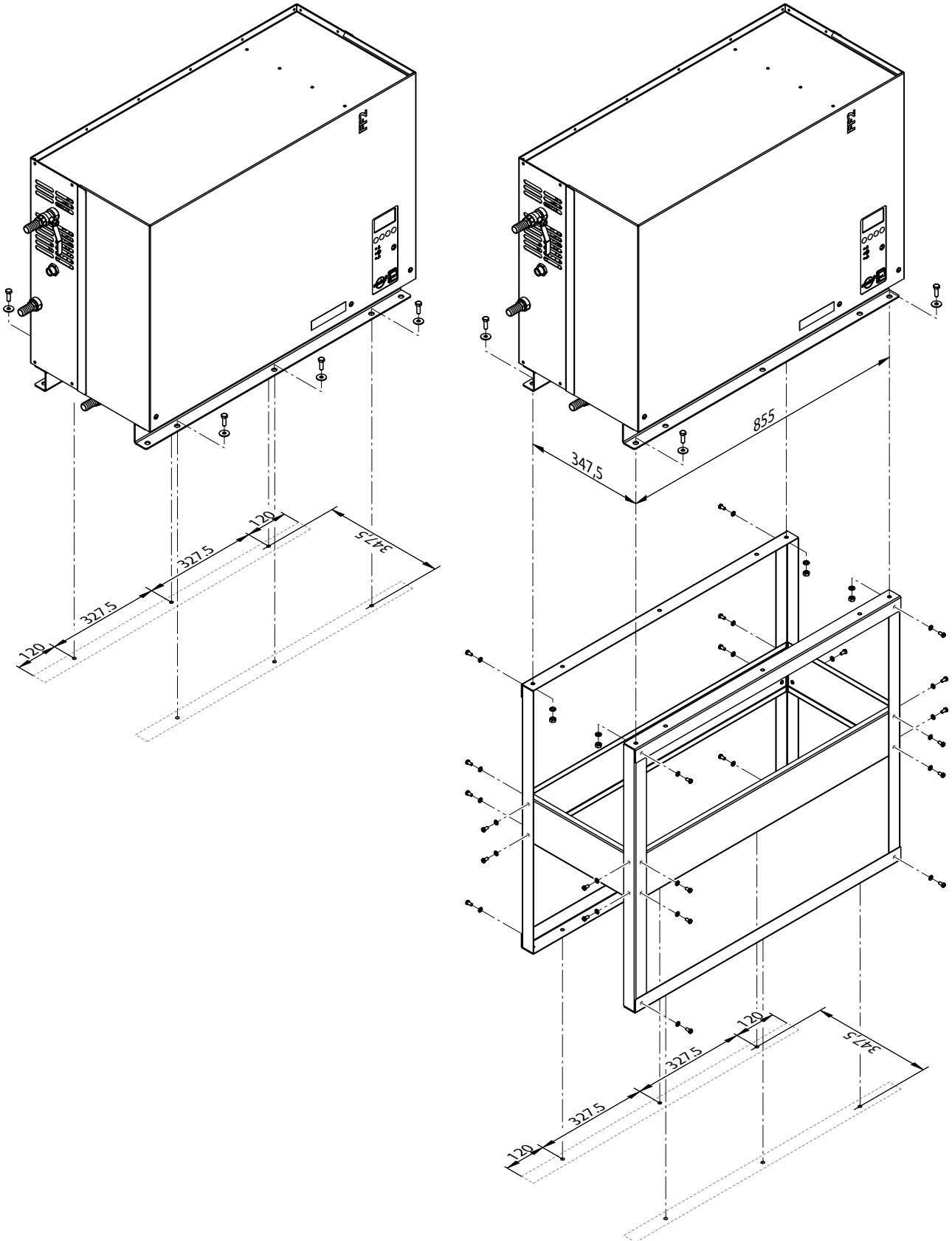

5.3.4 Water installation

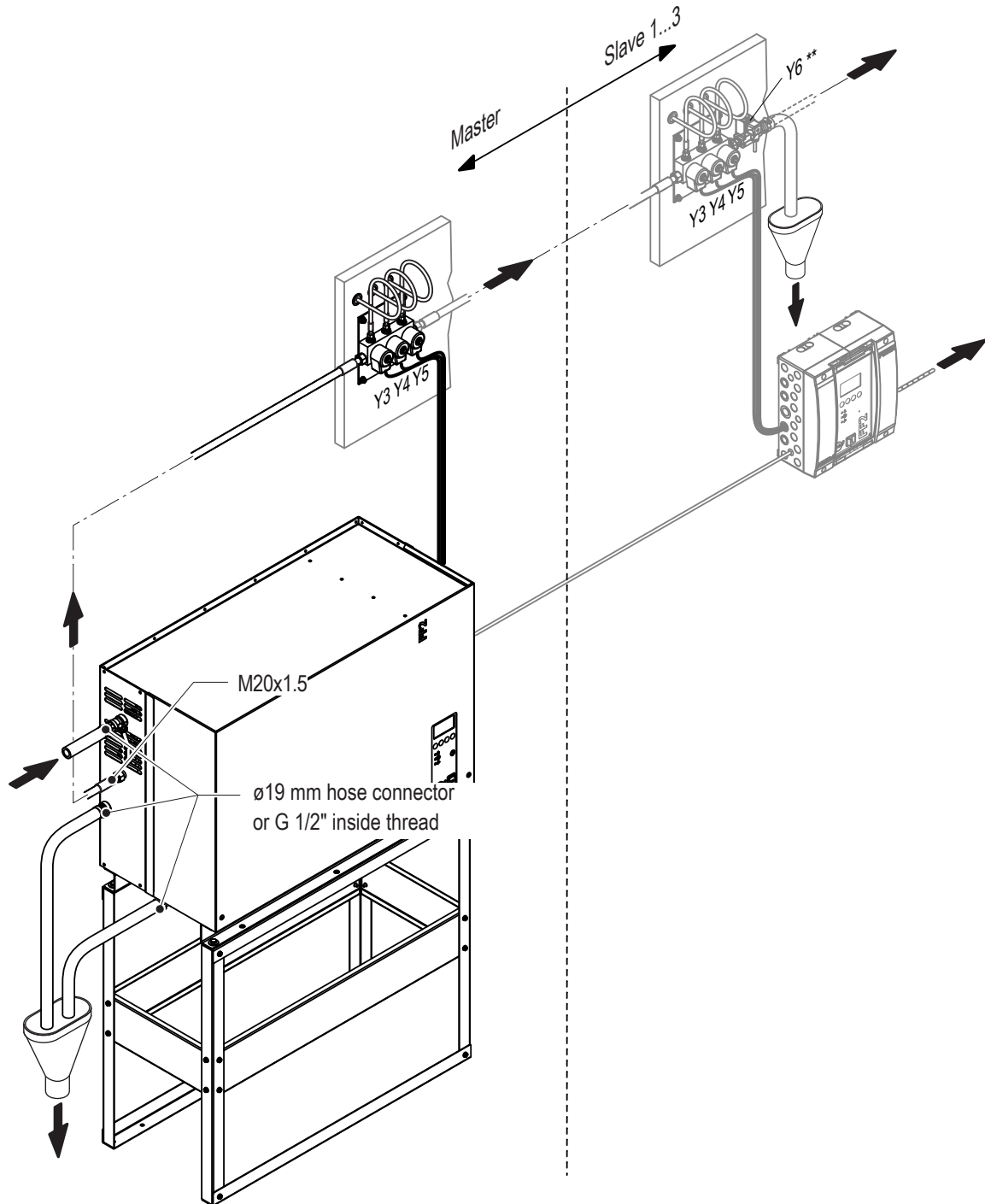

Notes on water installation

- Use hoses to connect the supply flushing line and the tub drain to an open drain funnel (make sure to install the hoses correctly).
- The working pressure flushing valve Y6 (**) is mounted directly to the step valve block of the Master unit (stand-alone system) or the last Slave unit (Compound systems). The drain hose of the flushing valve is to be connected to an open drain funnel (make sure to install the hose correctly).
- Use only the optional high-pressure hoses to establish the high-pressure piping between the high-pressure connection of the pump station and the step valve block (or between step valve blocks of the Slave units, respectively). Other hoses may get damaged in operation and cause system breakdown.

- **Important! Before connecting, all water hoses must be flushed with fully demineralized water for at least 10 minutes.** Remove the sealing caps from the connectors just shortly before installing the hoses.
- Install the high-pressure hoses in a way that they do not get in touch with each other or other system components. Where this is not possible for any reason protect the high-pressure hoses using the supplied anti-chafe spiral hose. In the locations exposed to chafing wrap the anti-chafe spiral hose helically around the high-pressure hoses(s).

5.4 Mounting the control unit FF2 Slave

CAUTION!

The **electronic components** inside the control unit are **very sensitive to electrostatic discharge**. When the unit is open for installation work, appropriate measures must be taken to **protect these components against damage caused by electrostatic discharge (ESD protection)**.

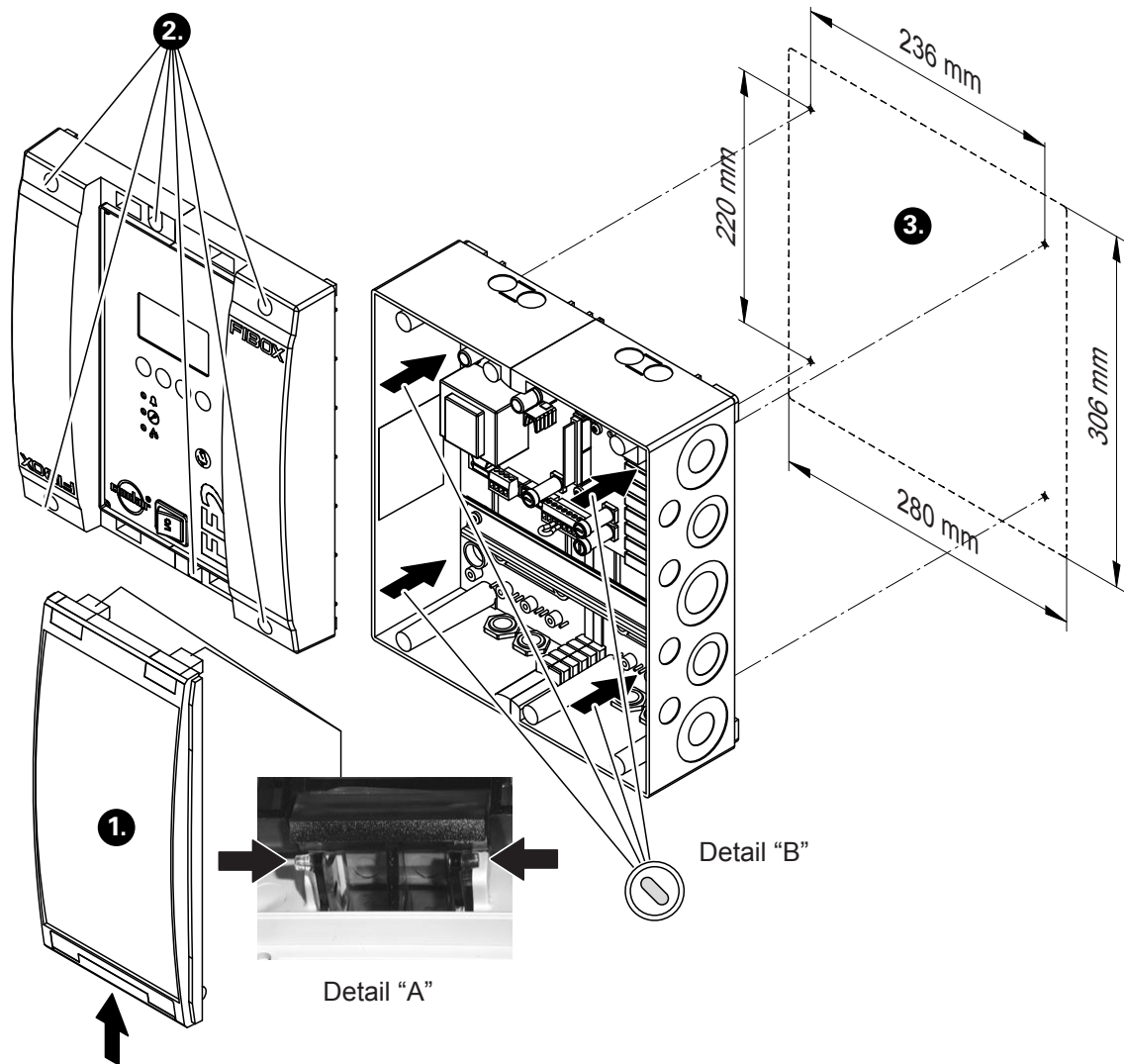

1. Unlock and swivel up the transparent cover, then unlock the two hinges (see detail "A") and remove the cover.
2. Undo the 6 screws, then carefully lift the control unit cover and disconnect the cables on the electronic.
3. Break out the 4 oblong holes in the bottom of the unit housing and fix the control unit to the wall using 4 screws.
4. Connect the voltage supply, the control signal, etc. to the corresponding terminals in the control unit according to the appropriate wiring diagram (see chapter 5.5.2).
Important: all cables must be lead into the control unit via the cable glands.

5.5 Electrical installation

5.5.1 Wiring diagram Master units (stand-alone units)

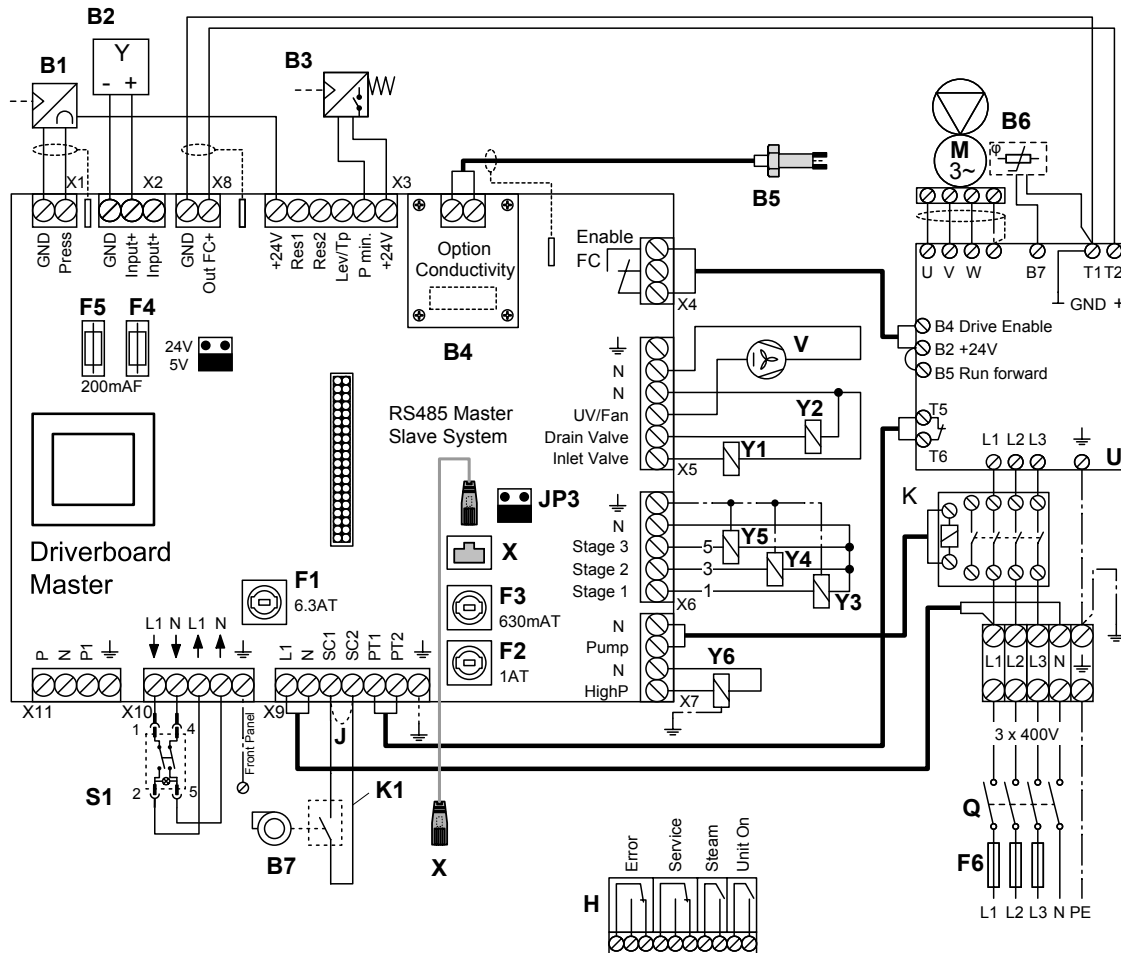

- | | | | |
|-----|--|----|---|
| B1 | Pressure transmitter 1...10V | K1 | External safety chain (safety humidistat, flow control, ventilator interlock, etc.) |
| B2 | Active humidity controller or humidity sensor | M | Motor high-pressure pump |
| B3 | Minimum pressure switch (supply pressure) | Q | External service switch (min. contact clearance 3 mm) or plug-type connector (installation mandatory) |
| B4 | Conductivity monitoring print (option) | S1 | Unit switch |
| B5 | Conductivity sensor (option) | U | Frequency converter pump motor |
| B6 | Temperature sensor motor coil | V | Ventilator pump motor |
| B7 | Ventilator interlock | X | Bus connection Master-Slave systems |
| F1 | Fuse 6.3A, slow-acting (power supply control unit) | Y1 | Supply valve |
| F2 | Fuse 1A, slow-acting (Relay 230V) | Y2 | Flushing valve supply pressure |
| F3 | Fuse 630mA, quick-acting (step valves) | Y3 | Step valve 1/7 |
| F4 | Fuse 200mA, quick-acting (analogue entry) | Y4 | Step valve 2/7 |
| F5 | Fuse 200mA, quick-acting (24 VDC supply) | Y5 | Step valve 4/7 |
| F6 | External fuse 10A, slow-acting (voltage supply 3x400V) | Y6 | Flushing valve working pressure (option) |
| H | Remote operating and fault indication (option) | | |
| J | Cable bridge (must be removed, if B7 is connected) | | |
| JP3 | Jumper must be set, if Slave unit is connected | | |
| K | Main contactor | | |

5.5.2 Wiring diagram Slave units

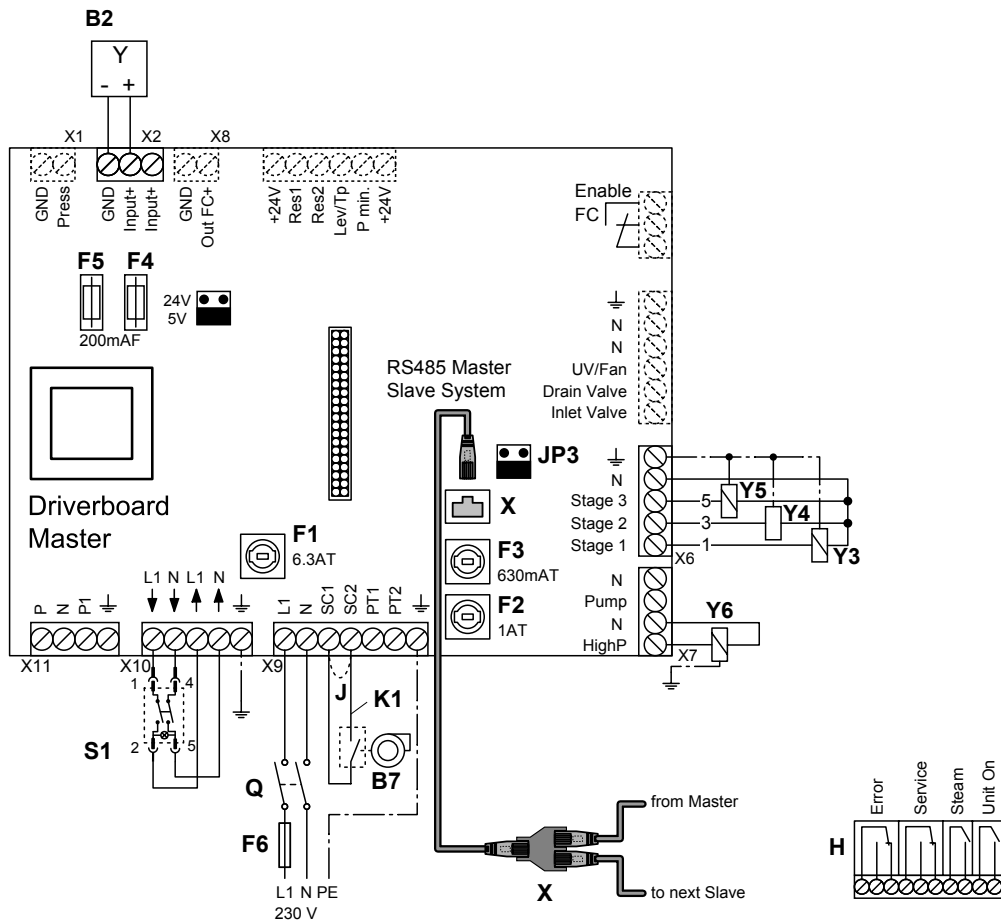

B2 Active humidity controller or humidity sensor
 B7 Ventilator interlock
 F1 Fuse 6.3A, slow-acting (power supply control unit)
 F2 Fuse 1A, slow-acting (Relay 230V)
 F3 Fuse 630mA, quick-acting (step valves)
 F4 Fuse 200mA, quick-acting (analogue entry)
 F5 Fuse 200mA, quick-acting (24 VDC supply)
 F6 External fuse 10A, slow-acting (voltage supply 3x400V)
 H Remote operating and fault indication (option)
 J Cable bridge (must be removed, if B7 is connected)
 JP3 Jumper must be set on last if Slave unit

K1 External safety chain (safety humidistat, flow control, ventilator interlock, etc.)
 Q External service switch (min. contact clearance 3 mm) or plug-type connector (installation mandatory)
 S1 Unit switch
 X Bus connection Master-Slave systems
 Y3 Step valve 1/7
 Y4 Step valve 2/7
 Y5 Step valve 4/7
 Y6 Flushing valve working pressure (option)

5.5.3 Notes on electric installation

- The electric installation must be carried out according to the wiring diagrams in chapters 5.5.1 and 5.5.2 and the applicable local regulations. All information given in the wiring diagram must be followed and observed.
- All cables must be lead into the unit via the cable openings.
- Make sure the cables do not scrub on any component.
- The supply voltage must comply with the voltage in the corresponding wiring diagram.

The electrical installation of the Condair FF2 includes:

Installation	Master	Slave
<p>Power supply Master: 380...400V/3N~/50-60Hz Slave: 230V/1N~/50-60Hz</p> <p>Connection of power supply to terminals L1, L2, L3, N and PE (Master) or L1, N and PE (Slave) respectively, according to the corresponding wiring diagram. The service switch Q (disconnects all 3 wires with a minimum contact clearance of 3 mm) and the fuses F6 (max. 10 A, slow-blow) are mandatory. Cable section according to the applicable local regulations.</p> <p>CAUTION!</p> <p>Before connecting make sure the local mains voltage and frequency meet the values stated on the rating plate of the pump station/Slave control unit.</p>	x	x
<p>Step valves (Y3, Y4 and Y5)</p> <p>Use the supplied cable to connect the step valves Y3, Y4 and Y5 to terminals X6 according the wiring diagram.</p> <p>Note: Consult the wiring diagram for the numbering of wires. In addition, the valve designations (Y3 ... Y5) are imprinted on the cable.</p> <p>Important: exclusively use the cable included in the delivery!</p>	x	x
<p>External controller or humidity sensor (B1 or B2)</p> <p>Connect external controller or humidity sensor to terminal X2.</p> <p>Admissible control signals see chapter 10.1.</p>		
<p>External safety chain (K1)</p> <p>Serial connection of potential-free contacts of external monitoring devices (safety humidistat, flow monitoring device, release switch, etc.) to terminals SC1 and SC2. Important! If no monitoring devices are connected a cable bridge (J) must be installed to the terminals SC1 and SC2.</p> <p>CAUTION!</p> <p>Do not connect any external voltage to terminals SC1 and SC2.</p>	x	x

Installation	Master	Slave
<p>Remote operation and fault indication (option)</p> <p>Four potential-free relay contacts are available for remote operation and fault indication. The following states of operation can be communicated remotely:</p> <ul style="list-style-type: none"> – “Error”: This relay is activated in case of malfunction. – “Humidification”: This relay closes when humidification starts. – “Maintenance”: This relay is activated if one of the preset maintenance counters expires. – “Unit on”: This relay closes when the control unit is powered up via the mains switch. <p>The maximum contact load is: 250V/5A.</p> <p>For actuating relays or small contactors use appropriate interference suppressors.</p>	x	x
<p>Flushing valve Y6 working pressure (option)</p> <p>Connect the flushing valve Y6 according to the wiring diagram to the terminals N and High P of the terminal block X7 using the supplied cable.</p>	x	x
<p>Interconnection Master-Slave</p> <p>Master and Slave(s) are interconnected according to the wiring diagrams via the RJ45 cable available as accessories.</p> <p>In addition the Jumper JP3 must be set on the driver board of the Master and the last Slave.</p>	x	x

Note: There are separate documentations available for RS485 Modbus and e-LINKS FF2.

6 Initial commissioning

It is mandatory that the initial commissioning is carried out by an authorised service technician of your Condair supplier according to the following check list. The check list must be filled out during the first commissioning and signed by the corresponding service technician.

6.1 Check list initial commissioning Condair FF2

Agency: _____ Client: _____
 Location: _____ Date: _____
 Pump: _____ Serial number: _____
 Nozzle type: _____ Humidification capacity: _____
 Demand signal: _____ Software version: _____

1. Visual inspection

Hoses properly fixed and anti-chafe spiral hose mounted, where necessary?	<input type="checkbox"/>
Connections high-pressure piping pump station - step valve block	<input type="checkbox"/>
Hose connections in the duct	<input type="checkbox"/>
Connection Y3 to spray circuit 1/7	<input type="checkbox"/>
Connection Y4 to spray circuit 2/7	<input type="checkbox"/>
Connection Y5 to spray circuit 4/7	<input type="checkbox"/>

2. Control/Configuration

<p>Are the electric installations of the Master and the Slaves (if available) correctly done in accordance with the appropriate wiring diagram? Specially observe:</p> <ul style="list-style-type: none"> – Are the cables of the step valves correctly connected? – Is the control signal correctly connected? – Is the external safety chain connected (Master and Slaves) or is the cable bridge J connected instead? – Is the power supply correctly connected and correctly fused? 	<input type="checkbox"/>
With compound systems: Is the terminating resistor JP3 set on the driver board of the Master and the last Slave.	<input type="checkbox"/>
<p>Are the control units (Master and Slave) correctly configured (switch on control units and check configuration). Specially observe:</p> <ul style="list-style-type: none"> – Is the control signal correctly configured (is the internal controller deactivated, if an external controller is connected) ? – Is the number of Slave units correctly configured in the control unit of the Master? – Is the power limit correctly configured? 	<input type="checkbox"/>

3. Pump station

Control of the oil level in the pump	<input type="checkbox"/>
Flush supply line for at least for 5...10 minutes --> then connect	<input type="checkbox"/>
Flush high-pressure piping for 5...10 minutes	<input type="checkbox"/>
Room equipped with floor drain?	<input type="checkbox"/>
Flushing line and housing drain connected and hoses secured?	<input type="checkbox"/>
Flow pressure 2...10 bar?	<input type="checkbox"/>
Stop valve open?	<input type="checkbox"/>
No leakages at the pump?	<input type="checkbox"/>

4. Nozzle unit

Nozzle pipes tight?	<input type="checkbox"/>
Drain within the humidification distance present and connected via a siphon? Does the height of the siphon comply with the expected duct pressure?	<input type="checkbox"/>
Spray angle of the nozzles (min. 50°, optimal 70°)	<input type="checkbox"/>
Minimum distance from the first nozzle to the duct wall accurate (no drop formation on the duct wall)?	<input type="checkbox"/>
Step 1/7	<input type="checkbox"/>
Step 2/7	<input type="checkbox"/>
Step 3/7	<input type="checkbox"/>
Step 4/7	<input type="checkbox"/>
Step 5/7	<input type="checkbox"/>
Step 6/7	<input type="checkbox"/>
Step 7/7	<input type="checkbox"/>

5. Droplet separator

Droplet separator correctly installed, according to the regulations of the manufacturer?	<input type="checkbox"/>
Drain after the droplet separator present and connected via a siphon? Does the height of the siphon comply with the expected duct pressure?	<input type="checkbox"/>
No drop throw after at least 1 hour of full load (fan and humidifier)	<input type="checkbox"/>

Remarks: _____

Date: _____

Signature: _____

7 Operation

7.1 Display and operating elements

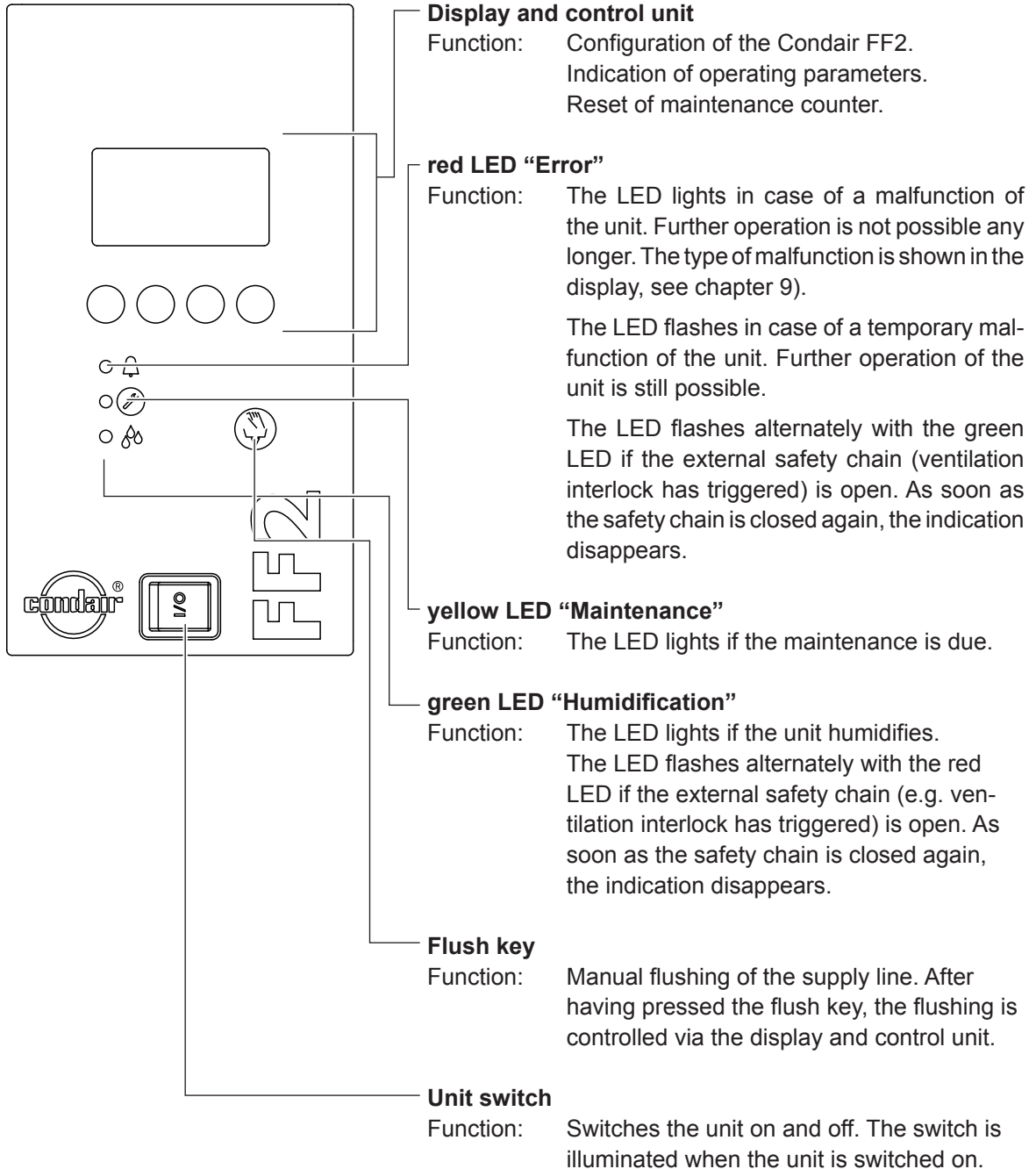

7.2 Setting the unit into operation

Important! The procedure described hereafter assumes that the system has been installed correctly and initial commissioning has been carried out duly by a service technician of the manufacturer/distributor.

Proceed as follows to set the Condair FF2 **into operation**:

1. Check all system components and installations for possible damage.



WARNING!

A damaged system or a system with damaged installations must not be set into operation.

2. Open the stop valve of the water supply line.
3. Activate the service switch of the power supply line to the pump station, and if present to the Slave control units.
4. Actuate the power switch of the pump station, and if present of the Slave control units.

The control carries out a **system test** and the supply line is flushed. During the test all three LED's light up temporarily and the display shows the opposite message.

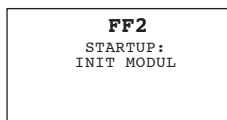

If a failure occurs during the system test, a corresponding error message is shown in the display.

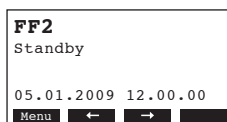

After the system test the unit is in **normal operation mode**. The display shows the **standard operating display** (first page of the indication level).

Note: The contents of the standard operating display depends on the actual operating status and on the configuration of the Condair FF2 and can differ from the opposite display.

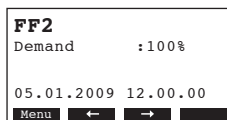

As soon as a humidity demand is present, the supply valve opens and the pump starts. As soon as the necessary working pressure is reached, one two or all three step valves open depending on the current demand and the Condair FF2 humidifies.

Note: If a humidity demand is present but since the last flushing of the supply line more than 1 hour has passed, the supply line is flushed first and then the pump is started.

Note: for detailed information regarding the operation of the control unit and the settings please observe the information given in the separate operating instructions to the control unit FF2.

7.3 Inspections during operation

During operation the Condair FF2 and the humidification system have to be inspected weekly. On this occasion check the following:

- the whole humidification system for any leakage.
- the nozzle unit and the other system components for correct fixing and any damage.
- the electric installation for any damage.
- the operating display for any warning or error message

If the inspection reveals any irregularities (e.g. leakage, error indication) or any damaged components take the Condair FF2 out of operation as described in chapter 7.4. Then, let the damage or malfunction be resolved by a qualified specialist or a service technician of your Condair supplier.

7.4 Setting the unit out of service

Important! For hygienic reasons we strongly recommend to leave the Condair FF2 on all the time, even in periods when no humidification is required. This way the water circuit is flushed on a regular schedule thus preventing the formation of unwanted microorganisms.

Proceed as follows to put the Condair FF2 out of service, e.g. for maintenance work:

1. Switch off the pump station and/or all Slave control units (if present).
2. Shut off the line supplying demineralized water from the reversing osmosis system and drain the line, as required.
3. Close the stop valve of the supply line and **secure it to prevent inadvertent opening**.
4. Switch on the pump station again and wait until automatic pressure relief has taken place (approx. 1 minute), then switch the pump station off again.
5. Turn off the service switch in the mains supply lines to the pump station and to the Slave control units (if present), **then secure the service switches against inadvertent switching on**.
6. **Hygiene! Let the fan of the ventilation system run until the humidifier unit is dry.**
7. In case you need to carry out maintenance work, switch the ventilation unit off and secure it to prevent inadvertent power up (see instruction manual of the ventilation system).

8 Maintenance and replacement of components

8.1 Important notes on maintenance

Qualification of personnel

All maintenance work must be carried out only by **well qualified and trained personnel authorised by the owner**.

Maintenance and repair of the electrical installation of the Condair FF2 must be carried out only by qualified personnel (e.g. electrician) being aware of possible danger and implications.

It is the owner's responsibility to verify proper qualification of the personnel.

General note

The instructions and details for maintenance work must be followed and upheld.

Only the maintenance work described in this documentation may be carried out.

Only use original Condair spare parts to replace faulty parts.

Safety

Before maintenance is initiated, the Condair FF2 must be taken out of operation in accordance with instructions in chapter 7.4 and protected against unintentional switching on. Before servicing the humidification unit, the ventilation system must be set out of operation (consult the documentation of the ventilation system).

The Condair FF2 must be cleaned in the required intervals and the cleaning work has to be carried out correctly.

WARNING!

Poorly maintained humidification systems may endanger health. Therefore it is mandatory to **observe the specified maintenance intervals** and to **carry out maintenance work in strict accordance with the instructions**.

8.2 Maintenance intervals

To ensure safe, hygienic and economic operation of the Condair FF2 its components must be periodically maintained. For that purpose the Condair FF2 has a **fixed adjusted maintenance counter**.

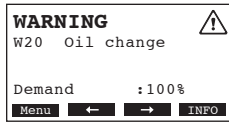

As soon as the set maintenance interval time has expired, the opposite maintenance message indicates that a maintenance or the oil change of the high-pressure pump is due.

A list of the work which has to be carried out can be found in chapter 8.3.

Important: the interval time for the first maintenance is fix set to 50 hours after the initial commissioning! Afterwards, the maintenance interval time changes automatically to **2000 hours**.

8.3 Maintenance work

System component	Work to be carried out
Pump station	Check water filter and clean, as required.
	Remove oil from pump replace with new oil (oil quality: HD-SAE 30 motor oil or 15 W40 multigrade oil) (see chapter 8.6). If the oil in the inspection glass is milky white (oil contains water) the piston packings must be replaced (see chapter 8.5.2).
	Check jetting pump and installations for leakage. Have defective components repaired or replaced by a Condair service technician
	Check electrical connections and wires. Have defective components repaired or replaced by a qualified technician.
Nozzle unit	Check screwing of base frame for proper fastening.
	In humidification mode set the nominal humidity value to 100 % and check the spraying angle of the spray nozzles (spraying cone: optimum 70°, 50° still admissible). If the check is successful set the nominal humidity back to the correct value. Remove spray nozzles (see chapter 8.5.1) and clean them in an ultrasonic bath, as required. Replace defective nozzles.
	Check hoses, tubing and connections for possible leakage. Fasten screwing or replace defective components, as required.
	Check nozzles for proper fastening. Moderately tighten (torque: approx. 4 Nm) nozzles with 13 mm open-end wrench, as required.

System component	Work to be carried out
Humidifier housing/ water tub	Check water tub (behind the droplet separators) for deposits or accumulation of water. If check reveals a considerable amount of accumulated water, check water drain and droplet separators. Note: Water drops and small accumulations of water in the tub behind the droplet separators are basically inherent to the system.
	Clean the water tub and the wet area of the humidifier housing (also behind the droplet separators) with a combined cleaning/disinfection agent. Then rinse all components with hygienically clean water from the reversing osmosis system and rub dry.
Droplet separator	See separate documentation of the droplet separator.
Checklist “Maintenance”	After having carried out all maintenance work, fill in the “Maintenance checklist”.

8.4 Resetting the maintenance indication

After completing maintenance work, the **maintenance indication** (yellow LED lights) must be reset.
Note: If the maintenance indication is not reset within 168 hours an error message is triggered.

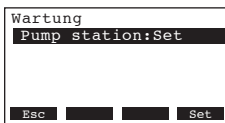

Select the maintenance menu:

Path: **Main menu > User > Password entry: 8808 > Maintenance**

Select “**Pump station**” in the maintenance menu, then press the **<Set>** key.

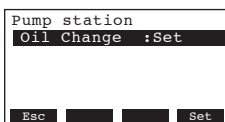

Select “**Oil Change**”, then press the **<Set>** key.

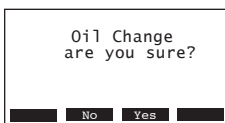

The reset dialogue shows up in the display. Press the **<Yes>** key to reset the **maintenance counter and the maintenance message**.

Note: Press the **<No>** key if you wish to abort the reset procedure.

To return to the standard operating display press the **<Esc>** key several times.

8.5 Removal of components

8.5.1 Removal and installation of spray nozzles

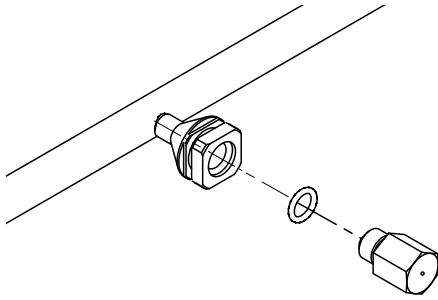

1. Put the system out of service according to chapter 7.4 and secure it to prevent inadvertent start-up.
2. Use a 13 mm open-end wrench to remove the spray nozzle.
3. Check O-ring, replace if necessary.
4. Screw in new or cleaned spray nozzle and moderately tighten (torque: 4 Nm) with open-end wrench.

8.5.2 Replacement of piston packings

The instructions for the replacement of the piston packings, is provided with the spare part set of the appropriate pump.

8.6 Changing the oil of the piston pump

 **WARNING!**

Strictly follow all local regulations on environmental protection when changing the oil. Bring the old oil to waste oil collecting point. In no case dispose of oil into the environment!

1. **Put the system out of service according to chapter 7.4 and secure it to prevent inadvertent start-up.**
2. Open the waste oil screw (depending on the model the screw is on the bottom or on the side of the pump) using a open-end wrench and let the oil drain into the existing oil tub.
Note: If the oil is milky white (oil contains water) the piston packings must be replaced (see chapter 7.5.2).
3. Install the waste oil screw and fasten it with the open-end wrench.
4. Carefully remove the oil tub, then empty the tub into a lockable waste oil container. Correctly dispose of the waste oil according the applicable local regulation.
5. Clean oil tub and relocate it under the pump again.
6. Remove the yellow-black oil filler cap and top up HD-SAE 30 motor oil or 15 W40 multigrade oil (approx. 0.4 l...1.0l depending on the model) until the level is just in the middle of the inspection glass (located above the waste oil screw).
7. Relocate the oil filler cap.

9 Troubleshooting

9.1 Important notes on troubleshooting

Qualification of personnel

Have faults eliminated by **adequately qualified and trained personnel** only. **Malfunctions caused by the electrical installation must be repaired by authorized personnel (e.g. electrician) only.**

Repair work on the high pressure pump may only be carried out by your Condair representative's service technician.

Safety

When eliminating faults, the Condair FF2 **must be taken out of operation**, as described in chapter 7.4, and prevented from further inadvertent operation.

Make sure the power supply to the pump station /Slave control units is cut off (test with voltage tester) and that the stop valve in the water supply line is closed.

9.2 Malfunction with error indication

Malfunctions during operation are indicated by a corresponding warning message (operation still possible, red LED flashes) or error message (operation not possible any longer, red LED lights) in the display of the pump station or the Slave control unit. Detailed information thereto can be found in the separate operating instructions for FF2 control unit.

9.3 Resetting the error indication

To reset the error indication:

Disconnect the pump station/Slave control unit from the mains for approx. 5 seconds, then reconnect again.

Note: If the fault has not been eliminated, the error indication reappears after a short while.

9.4 Malfunction without error indication

The following table provides errors that do not issue messages, notes on the cause of malfunction and information on how to eliminate the source of trouble.

Error	Cause	Remedy
Water deposits in the duct section outside of the water tub	Droplet separator defective.	Check/Replace droplet separator
	Excess air velocity (>4 m/s) in duct.	Reduce air velocity in duct (<4 m/s).
	Faulty location of spray nozzles or spraying circuits not connected to appropriate nozzles.	Check location of nozzles and piping of spraying circuits according to the nozzle diagram.
Condair FF2 humidifies permanently.	Nominal humidity value too high.	Reduce nominal humidity value.
	Ambient humidity very low.	No measures to be taken, just wait.
	The internal controller is activated, although an external controller is connected	Deactivate internal controller.
Maximum humidification capacity not reached.	Wrong system design (capacity too low).	Contact your Condair supplier.
	Step valve(s) Y3, Y4 or Y5 defective.	Check the function of the step valves by increasing the nominal humidity value. Important! Reset the nominal humidity to the correct value after checking.
	Spray nozzles clogged.	Remove nozzles (see chapter 8.5.1) and clean or replace them
	Hoses to nozzle pipes are leaking or disconnected, or nozzle pipes are leaking.	Check hoses/nozzle pipes and seal, as required
Control unit is switched on but the display of the control unit does not show anything.	Service switch in power supply line is off.	Set service switch in power supply line to On position.
	Fuses F6 of the power supply line blown	Have an electrician replace fuses F6 of the power supply line.
	Fuse F1 of control unit blown	Have an electrician replace fuse F1 of the control unit (see chapter 9.5).
	Display or control board defective	Have a Condair service technician replace the display or the control board.

Error	Cause	Remedy
Excessive fluctuations of humidity control.	Faulty electrical connection of spray valves Y3, Y4 and Y5 or spraying circuits not connected to appropriate nozzles.	Have an electrician connect spray valves Y3, Y4 and Y5 correctly (see wiring diagram). Check piping of spraying circuits and rectify, as required
During a humidification cycle water is flowing via the drain line into the funnel although there is no flushing.	Flushing valve Y2 (supply line) soiled or defective.	Have an expert check/clean or replace flushing valve Y2.
	Safety valve (supply pressure or working pressure) wrongly set, soiled or defective.	Have an expert correctly set up, clean or replace the safety valves (supply pressure: 8 bar, working pressure: 100 bar).

9.5 Replacing the fuse of the control unit

⚠ DANGER!

Danger of electric shock! One may get in touch with live parts when the pump station/ control unit is open. Touching live parts may cause severe injury or danger to life.

Therefore, before opening the pump station/control unit: switch off the pump station/control unit, disconnect it from the mains and protect it against inadvertent switching on.

CAUTION!

The **electronic components** inside the control unit are **very sensitive to electrostatic discharge**. When carrying out work on the open unit, appropriate measures must be taken to protect these components against damage caused by electrostatic discharge (ESD protection).

Replacement of the control unit fuses must be carried out **by qualified and authorised personnel only** (e.g. electrician).

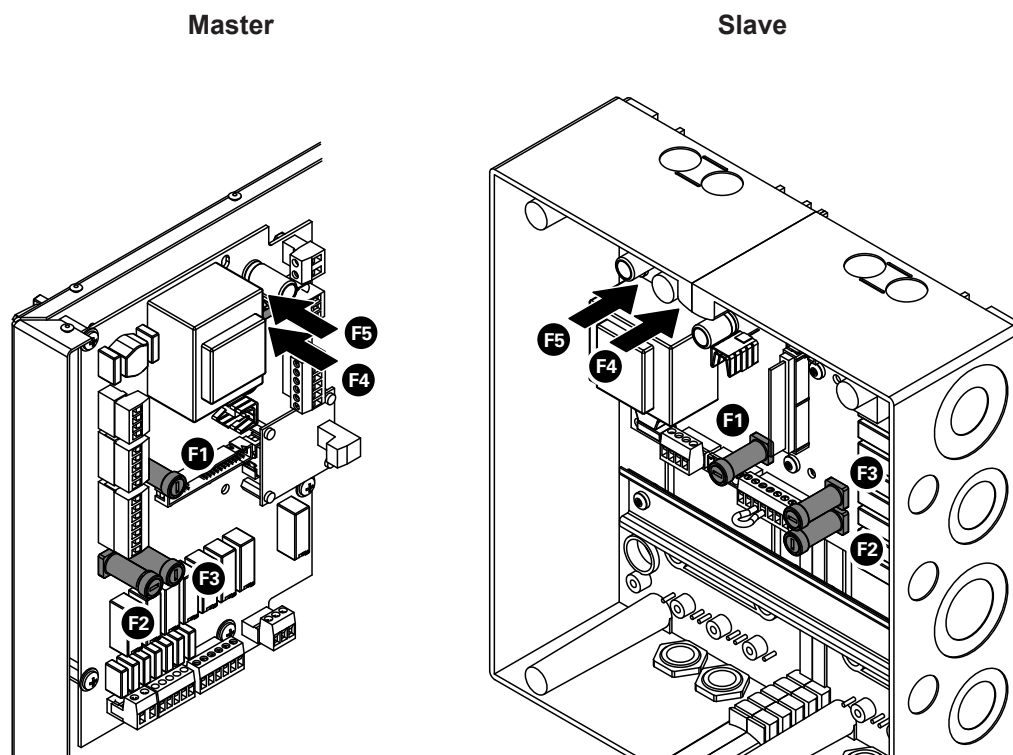

Location of the fuses/Notes on replacing the fuses

Designation	Type	Remarks
F1	6.3 A, slow-acting	Voltage supply control unit
F2	1 A, slow-acting	Relay 230 V
F3	630 mA, slow-acting	Step valves
F4	200 mA, quick-acting	Analogue input
F5	200 mA, quick-acting	24 VDC voltage supply

10 Product data

10.1 Technical specifications/ambient conditions

Humidifier unit	
built-in length	min 1.3 m
Specification of filter before humidifier	min. F7
Max. supply air temperature before humidifier	50 °C
Air velocity, range of use	0.5 ... 4.0 m/s
Loss of pressure with regard to cross-section of duct	approx. 75 Pa at wL 2.3 m/s
Nozzle capacities (at 80 bar spray pressure)	5 kg/h
Effective humidification distance	0.8...1.3 m
Humidification capacity	35....1080 kg/h
Pump station (control and jetting pump)	
Dimensions of pump station (Height x Width x Depth)	904 x 662 x 404 mm
Weight of pump station	max. 80 kg
Jetting pump supply voltage	380...400V/3N~/50...60Hz
Active output of jetting pump motor	1.5 kW / 4.0 kW
Current consumption of jetting pump motor	1.7...4.3 A / 4.4...6.9 A
Power consumption of control	60 VA
Working pressure of jetting pump (Standard)	80 bar
Oil capacity of jetting pump (capacity depending on pump size)	approx. 0.4 l ... 1.0 l
Admissible supply water temperature before jetting pump	5...35 °C
Admissible water pressure (yield pressure) before jetting pump	2...10 bar
Admissible conductivity of water supplied by RO system	3 ... 15 µS/cm no additives, max. 100 KBE/ml
Control signals	0...10 VDC, 2...10 VDC 0...5 VDC, 1...5 VDC, 0...16 VDC, 3,2...16 VDC, 0...20 mA, 4...20 mA
Control accuracy	up to ±4 %rh
Water supply connection	19 mm hose connector or G 1/2" inside thread
Flushing line connection	19 mm hose connector or G 1/2" inside thread
Tub drain connection	19 mm hose connector or G 1/2" inside thread
Connector high-pressure hose	M20x1.5 (outside thread)
Admissible ambient temperature	5 ... 35 °C
Admissible ambient humidity	max. 75 %rh, non-condensing
Test certificates	CE approval mark
Protection class of jetting pump/control	IP31

10.2 Declaration of conformity

We declare under our sole responsibility that the pump station used in the adiabatic high-pressure humidifier Condair FF2 comply with the following standards:

- EN 292-1
- EN 292-2
- EN 50081-1 (1992)
- EN 50082-2 (1995)
- EN 61000-4-2 (1995)
- EN 61000-4-3 (1996)
- EN 61000-4-4 (1995)
- EN 61000-4-5 (1995)
- EN 61000-4-6 (1996)
- EN 61000-4-8 (1993)
- EN 61000-4-11 (1994)

Walter Meier (Klima International) AG
Pfäffikon, January 5, 2009

10 Appendix

10.1 Diagram h,x

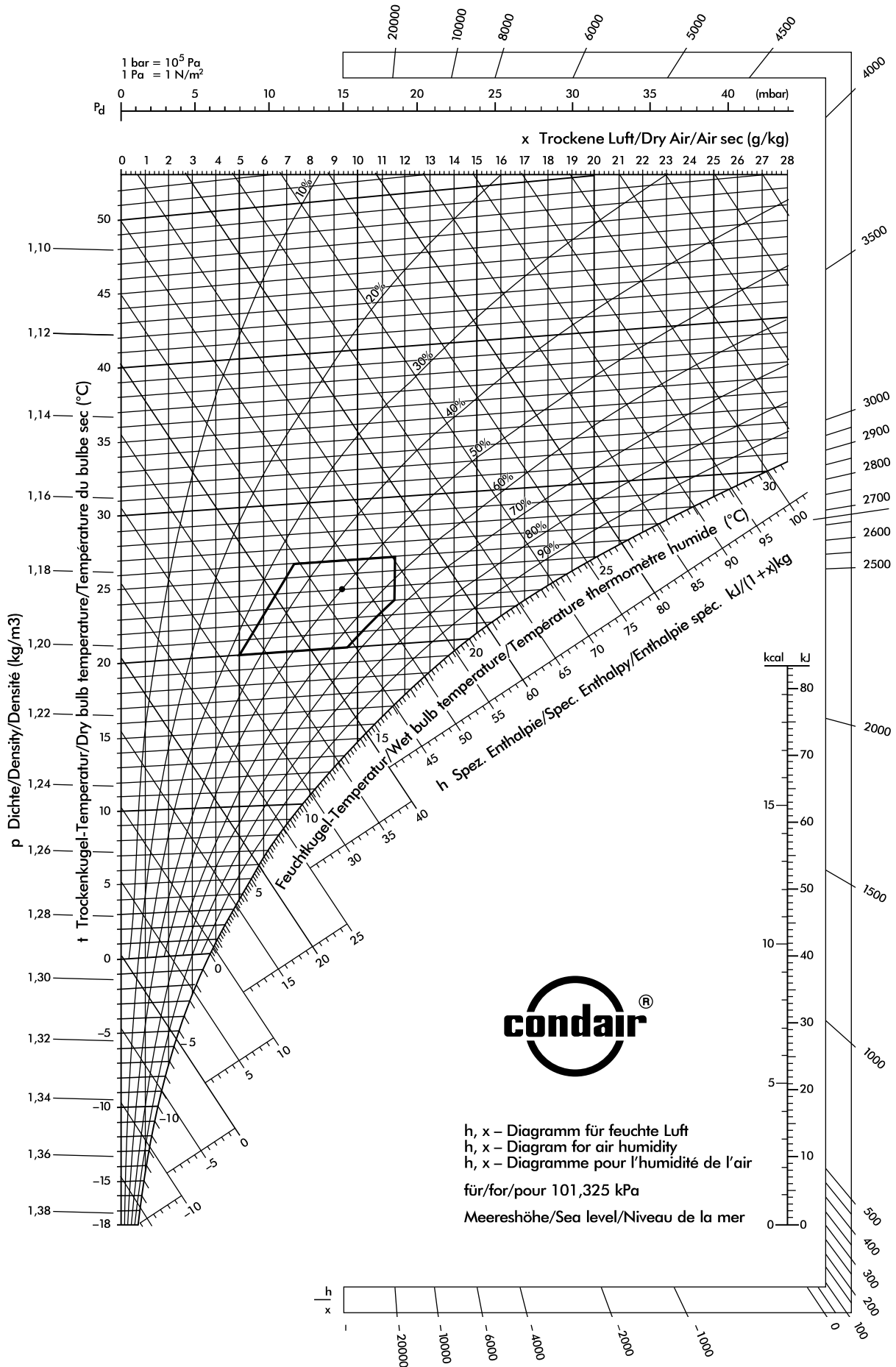

Condair FF2



Maintenance record

Unit type	Serial number	Commissioning	Software version	Location	Responsible	Internal no.

Date	Time	Permeat conduc- tance (if possible) [μS/cm]	Load pressure before pump [bar]	Load pressure after pump [bar]	Working hours [h]	Remarks regarding the maintenance	Signature

Notes

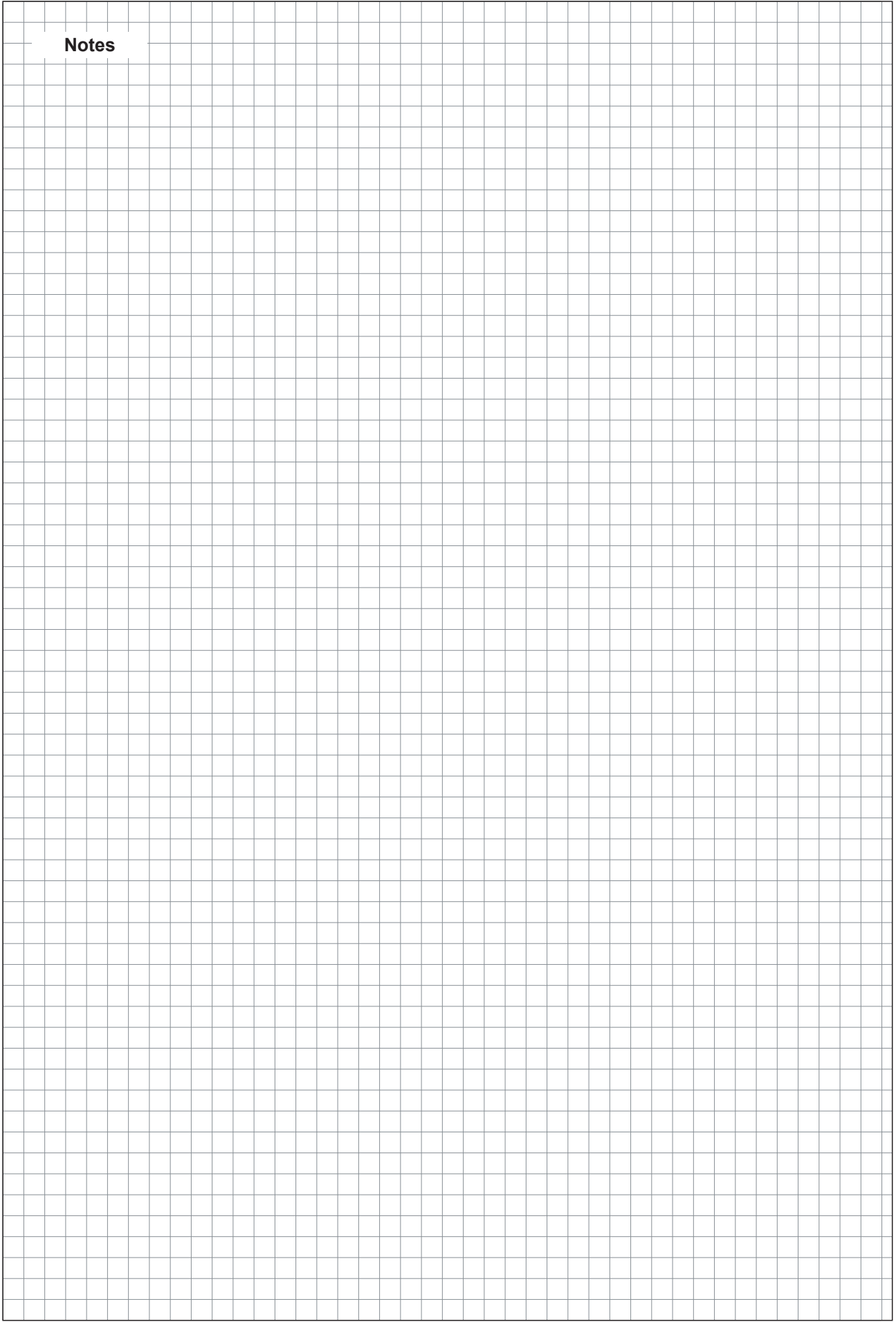



CONSULTING, SALES AND SERVICE:

Solutions for Indoor Climate



Reg.No. 40002-2

Manufacturer:

Walter Meier (Climate International) Ltd.

Talstr. 35-37, P.O. Box, CH-8808 Pfäffikon (Switzerland)

Phone +41 55 416 61 11, Fax +41 55 416 62 62

www.waltermeier.com, international.climate@waltermeier.com

**walter
meier**